



**TOLL FREE 1-800-392-0146**

[www.hoist-parts.com](http://www.hoist-parts.com)  
[parts@sisscohoist.com](mailto:parts@sisscohoist.com)

**SISSCO ONLINE HOIST PARTS DISTRIBUTION CENTER MANUALS**



***A Reputation for Service Since 1972***  
***Certified WBE***



**INSTRUCTIONS  
AND  
PARTS LIST**



**SINGLE GIRDER  
UNDERHUNG CRANE  
BRIDGE KITS  
1/2 THRU 10 TON  
HAND GEARED  
AND  
MOTOR DRIVEN**



**COLUMBUS MCKINNON MATERIAL LISTED BELOW IS REQUIRED TO BUILD THESE BRIDGE CRANES**

**HAND GEARED BRIDGE:**

For Spans Thru (Feet)	Cross Shaft Bearing Ass'y		Cross Shaft Coupling		Hand Chain Wheel and Guide - 1 Ass'y Req'd	Hand Chain with Open Link (36 Feet)
	Number Req'd	Catalog Number	Number Req'd	Catalog Number		
10	1		2		913115	8282
22	2		2			
28	3		3			
36	4	904625	3	8280		
42	5		4			
52	6		4			
60	7		4			

**THESE TRUCKS COMMON TO ALL BRIDGES**

One Pair of End Trucks				
Rated Load Range (Tons)	For Spans Thru (Feet)	Runway Flange Width (Inches)	Catalog Number	Wheel Diameter (Inches)
1/2 thru 5	52	4-5/8 thru 6 6-1/8 thru 8-1/2 8-5/8 thru 11	913101 913101W1 913101W2	6-1/2
	60	4-5/8 thru 6 6-1/8 thru 8-1/2 8-5/8 thru 11	913102 913102W1 913102W2	
5 thru 10	52	5 thru 7 7-1/8 thru 9-1/2 9-5/8 thru 12	913106 913106W1 913106W2	8
	60	5 thru 7 7-1/8 thru 9-1/2 9-5/8 thru 12	913107 913107W1 913107W2	

**INDIVIDUAL DRIVE – MOTOR DRIVEN BRIDGE:**

Rated Load Range (Tons)	Speed (FPM)	Motors (2 Req'd)				115V Control		
		HP	208-230V	460V	575V	208-230V	460V	575V
<b>SINGLE SPEED</b>								
1/2 thru 5	ALL	1/2	905381	905381	905382	913155	905386	905387
	50	1/2	905381	905381	905382	913155	905386	905387
5 thru 10	65	3/4	913120	913120	913121	913158	913156	913157
	100	1	913124	913124	913125	913158	913156	913157
<b>TWO SPEED</b>								
1/2 thru 5	ALL	.5/17	905394	905395	905396	913165	905398	905399
	50/17	.5/17	905394	905395	905396	913165	905398	905399
	65/22	.75/25	913132	913133	913134	913168	913166	913167
5 thru 10	100/33	1/33	913139	913140	913141	913168	913166	913167

Gear Reducers (2 Required)		
20:1 Ratio (50 FPM)	15:1 Ratio (65 FPM)	10:1 Ratio (100 FPM)
913112	913111	913110

Fused Disconnect Switch	
208-230V	460-575V
913090	913091

1 Pair of End Trucks – See Truck Chart.

**CENTER DRIVE – MOTOR DRIVEN BRIDGE:**

Rated Load Range (Tons)	Speed (FPM)	Motors (1 Req'd)				115V Control		
		HP	208-230V	460V	575V	208-230V	460V	575V
<b>SINGLE SPEED</b>								
1/2 thru 5	ALL	3/4	913120	913120	913121	913155	905386	905387
	50	3/4	913120	913120	913121	913155	905386	905387
5 thru 10	65	1	913124	913124	913125	913155	905386	905387
	100	1-1/2	913128	913128	913129	913158	913156	905387
<b>TWO SPEED</b>								
1/2 thru 5	ALL	3/4	913132	913133	913134	913165	905398	905399
	50/17	3/4	913132	913133	913134	913165	905398	905399
	65/22	1	913139	913140	913141	913165	905398	905399
5 thru 10	100/33	1-1/2	913145	913146	913147	913168	913166	905399

1 Pair of End Trucks – See Truck Chart.

For Spans Thru (Feet)	Cross Shaft Bearing Ass'y		Cross Shaft Coupling	
	Number Req'd	Catalog Number	Number Req'd	Catalog Number
12	2		4	
20	4		4	
30	6	904625	4	8280
40	8		4	
50	10		6	
60	12		6	

Gear Reducers (1 Required)		
20:1 Ratio (50 FPM)	15:1 Ratio (65 FPM)	10:1 Ratio (100 FPM)
913112	913111	913110

Fused Disconnect Switch	
208-230V	460-575V
913090	913091



**SIZES OF BRIDGES THAT CAN BE BUILT WITH THESE KITS (S BRIDGE BEAM)**

**(\*\*) BEAM SIZES FOR VARIOUS SPANS  
(\* ) RATED LOAD IN TONS**

SPANS		SPANS											
TO	1/2	1	1-1/2	2	3	4	5	6	7-1/2	8	10	TO	
<b>Hand Geared Crane</b>													
10ft.	S7x15.3	S7x15.3	S8x18.4	S10x25.4	S12x40.8	S12x40.8	S12x40.8	S18x54.7	S20x66	S18x54.7	S20x66	S20x66	10ft.
12ft.	S7x15.3	S7x15.3	S10x25.4	S10x25.4	S12x40.8	S12x40.8	S12x40.8	S18x54.7	S20x66	S18x54.7	S20x66	S20x66	12ft.
14ft.	S7x15.3	S7x15.3	S10x25.4	S12x31.8	S12x40.8	S12x40.8	S12x40.8	S18x54.7	S20x66	S18x54.7	S20x66	S20x66	14ft.
16ft.	S7x15.3	S8x18.4	S10x25.4	S12x31.8	S12x40.8	S12x40.8	S12x40.8	S18x54.7	S20x66	S20x66	S20x66	S20x66	16ft.
18ft.	S7x15.3	S10x25.4	S10x25.4	S12x31.8	S12x40.8	S12x40.8	S12x40.8	S18x54.7	S20x66	S20x66	S20x66	S20x66	18ft.
20ft.	S8x18.4	S10x25.4	S12x31.8	S12x31.8	S12x40.8	S12x40.8	S12x40.8	S18x54.7	S20x66	S20x66	S20x66	S20x66	20ft.
22ft.	S10x25.4	S10x25.4	S12x31.8	S12x40.8	S12x40.8	S12x40.8	S12x40.8	S18x54.7	S20x66	S20x66	S20x66	S20x66	22ft.
24ft.	S10x25.4	S12x31.8	S12x40.8	S12x40.8	S12x40.8	S12x40.8	S12x40.8	S18x54.7	S20x66	S20x66	S20x66	S20x66	24ft.
26ft.	S10x25.4	S12x31.8	S12x40.8	S12x40.8	S12x40.8	S12x40.8	S12x40.8	S18x54.7	S20x66	S20x66	S20x66	S20x66	26ft.
28ft.	S10x25.4	S12x31.8	S12x40.8	S12x40.8	S12x40.8	S12x40.8	S12x40.8	S18x54.7	S20x66	S20x66	S20x66	S20x66	28ft.
30ft.	S12x31.8	S12x40.8	S12x40.8	S12x40.8	S12x40.8	S12x40.8	S12x40.8	S18x54.7	S20x66	S20x66	S20x66	S20x66	30ft.
32ft.	S12x31.8	S12x40.8	S12x40.8	S12x40.8	S12x40.8	S12x40.8	S12x40.8	S18x54.7	S20x66	S20x66	S20x66	S20x66	32ft.
34ft.	S12x40.8	S15x42.9	S18x54.7	S18x54.7	S18x54.7	S18x54.7	S18x54.7	S18x54.7	S18x54.7	S18x54.7	S18x54.7	S18x54.7	34ft.
36ft.	S12x40.8	S18x54.7	S15x42.9	S15x42.9	S15x42.9	S15x42.9	S15x42.9	S15x42.9	S15x42.9	S15x42.9	S15x42.9	S15x42.9	36ft.
38ft.	S12x40.8	S18x54.7	S15x42.9	S15x42.9	S15x42.9	S15x42.9	S15x42.9	S15x42.9	S15x42.9	S15x42.9	S15x42.9	S15x42.9	38ft.
40ft.	S18x54.7	S15x42.9	S15x42.9	S15x42.9	S15x42.9	S15x42.9	S15x42.9	S15x42.9	S15x42.9	S15x42.9	S15x42.9	S15x42.9	40ft.
42ft.	S18x54.7	S15x42.9	S15x42.9	S15x42.9	S15x42.9	S15x42.9	S15x42.9	S15x42.9	S15x42.9	S15x42.9	S15x42.9	S15x42.9	42ft.
44ft.	S18x54.7	S15x42.9	S15x42.9	S15x42.9	S15x42.9	S15x42.9	S15x42.9	S15x42.9	S15x42.9	S15x42.9	S15x42.9	S15x42.9	44ft.
46ft.	S18x54.7	S15x42.9	S15x42.9	S15x42.9	S15x42.9	S15x42.9	S15x42.9	S15x42.9	S15x42.9	S15x42.9	S15x42.9	S15x42.9	46ft.
48ft.	S18x54.7	S15x42.9	S15x42.9	S15x42.9	S15x42.9	S15x42.9	S15x42.9	S15x42.9	S15x42.9	S15x42.9	S15x42.9	S15x42.9	48ft.
50ft.	S18x54.7	S15x42.9	S15x42.9	S15x42.9	S15x42.9	S15x42.9	S15x42.9	S15x42.9	S15x42.9	S15x42.9	S15x42.9	S15x42.9	50ft.
52ft.	S18x54.7	S15x42.9	S15x42.9	S15x42.9	S15x42.9	S15x42.9	S15x42.9	S15x42.9	S15x42.9	S15x42.9	S15x42.9	S15x42.9	52ft.
54ft.	S18x54.7	S15x42.9	S15x42.9	S15x42.9	S15x42.9	S15x42.9	S15x42.9	S15x42.9	S15x42.9	S15x42.9	S15x42.9	S15x42.9	54ft.
56ft.	S18x54.7	S15x42.9	S15x42.9	S15x42.9	S15x42.9	S15x42.9	S15x42.9	S15x42.9	S15x42.9	S15x42.9	S15x42.9	S15x42.9	56ft.
58ft.	S18x54.7	S15x42.9	S15x42.9	S15x42.9	S15x42.9	S15x42.9	S15x42.9	S15x42.9	S15x42.9	S15x42.9	S15x42.9	S15x42.9	58ft.
60ft.	S18x54.7	S15x42.9	S15x42.9	S15x42.9	S15x42.9	S15x42.9	S15x42.9	S15x42.9	S15x42.9	S15x42.9	S15x42.9	S15x42.9	60ft.
<b>Motor Driven Crane - Individual Drive</b>													
10ft.	S7x15.3	S7x15.3	S10x25.4	S10x25.4	S12x40.8	S12x40.8	S12x40.8	S18x54.7	S20x66	S18x54.7	S20x66	S20x66	10ft.
12ft.	S7x15.3	S7x15.3	S10x25.4	S10x25.4	S12x40.8	S12x40.8	S12x40.8	S18x54.7	S20x66	S18x54.7	S20x66	S20x66	12ft.
14ft.	S7x15.3	S7x15.3	S10x25.4	S10x25.4	S12x40.8	S12x40.8	S12x40.8	S18x54.7	S20x66	S18x54.7	S20x66	S20x66	14ft.
16ft.	S7x15.3	S8x18.4	S10x25.4	S12x31.8	S12x40.8	S12x40.8	S12x40.8	S18x54.7	S20x66	S18x54.7	S20x66	S20x66	16ft.
18ft.	S8x18.4	S10x25.4	S12x31.8	S12x31.8	S12x40.8	S12x40.8	S12x40.8	S18x54.7	S20x66	S18x54.7	S20x66	S20x66	18ft.
20ft.	S8x18.4	S10x25.4	S12x31.8	S12x40.8	S12x40.8	S12x40.8	S12x40.8	S18x54.7	S20x66	S18x54.7	S20x66	S20x66	20ft.
22ft.	S10x25.4	S12x31.8	S12x40.8	S12x40.8	S12x40.8	S12x40.8	S12x40.8	S18x54.7	S20x66	S18x54.7	S20x66	S20x66	22ft.
24ft.	S10x25.4	S12x31.8	S12x40.8	S12x40.8	S12x40.8	S12x40.8	S12x40.8	S18x54.7	S20x66	S18x54.7	S20x66	S20x66	24ft.
26ft.	S10x25.4	S12x31.8	S12x40.8	S12x40.8	S12x40.8	S12x40.8	S12x40.8	S18x54.7	S20x66	S18x54.7	S20x66	S20x66	26ft.
28ft.	S12x31.8	S12x40.8	S12x40.8	S12x40.8	S12x40.8	S12x40.8	S12x40.8	S18x54.7	S20x66	S18x54.7	S20x66	S20x66	28ft.
30ft.	S12x31.8	S12x40.8	S12x40.8	S12x40.8	S12x40.8	S12x40.8	S12x40.8	S18x54.7	S20x66	S18x54.7	S20x66	S20x66	30ft.
32ft.	S12x40.8	S12x40.8	S12x40.8	S12x40.8	S12x40.8	S12x40.8	S12x40.8	S18x54.7	S20x66	S18x54.7	S20x66	S20x66	32ft.
34ft.	S12x40.8	S12x40.8	S12x40.8	S12x40.8	S12x40.8	S12x40.8	S12x40.8	S18x54.7	S20x66	S18x54.7	S20x66	S20x66	34ft.
36ft.	S12x40.8	S12x40.8	S12x40.8	S12x40.8	S12x40.8	S12x40.8	S12x40.8	S18x54.7	S20x66	S18x54.7	S20x66	S20x66	36ft.
38ft.	S12x40.8	S12x40.8	S12x40.8	S12x40.8	S12x40.8	S12x40.8	S12x40.8	S18x54.7	S20x66	S18x54.7	S20x66	S20x66	38ft.
40ft.	S12x40.8	S12x40.8	S12x40.8	S12x40.8	S12x40.8	S12x40.8	S12x40.8	S18x54.7	S20x66	S18x54.7	S20x66	S20x66	40ft.
42ft.	S12x40.8	S12x40.8	S12x40.8	S12x40.8	S12x40.8	S12x40.8	S12x40.8	S18x54.7	S20x66	S18x54.7	S20x66	S20x66	42ft.

**SIZES OF BRIDGES THAT CAN BE BUILT WITH THESE KITS (S BRIDGE BEAM)**

SPANS		(**) BEAM SIZES FOR VARIOUS SPANS										SPANS	
TO	1/2	1	1-1/2	2	3	4	5	6	7-1/2	8	10	TO	TO
<b>Motor Driven Crane – Individual Drive (Continued)</b>													
44ft.	S 15x42.9w/C8x11.5	S 15x42.9w/C8x11.5	S 18x54.7w/C9x13.4	S 18x54.7w/C9x13.4	S 20x66w/C10x15.3	S 20x66w/C12x20.7	S 24x80w/C12x20.7	S 24x100w/C12x20.7	S 24x106w/C12x20.7	S 24x106w/C12x20.7	S 24x121w/C15x40	44ft.	
46ft.	S 15x42.9w/C8x11.5	S 15x42.9w/C8x11.5	S 18x54.7w/C9x13.4	S 18x54.7w/C9x13.4	S 20x66w/C12x20.7	S 24x80w/C10x15.3	S 24x80w/C12x20.7	S 24x106w/C12x20.7	S 24x106w/C12x20.7	S 24x106w/C12x20.7	S 24x106w/C12x20.7	46ft.	
48ft.	S 15x42.9w/C8x11.5	S 18x54.7w/C9x13.4	S 18x54.7w/C9x13.4	S 20x66w/C10x15.3	S 20x66w/C12x20.7	S 24x80w/C12x20.7	S 24x80w/C12x20.7	S 24x106w/C12x20.7	S 24x106w/C12x20.7	S 24x106w/C12x20.7	S 24x106w/C12x20.7	48ft.	
50ft.	S 15x42.9w/C8x11.5	S 18x54.7w/C9x13.4	S 18x54.7w/C9x13.4	S 20x66w/C10x15.3	S 24x80w/C10x15.3	S 24x80w/C12x20.7	S 24x80w/C12x20.7	S 24x106w/C12x20.7	S 24x106w/C12x20.7	S 24x106w/C12x20.7	S 24x106w/C12x20.7	50ft.	
52ft.	S 18x54.7w/C9x13.4	S 18x54.7w/C9x13.4	S 20x66w/C10x15.3	S 20x66w/C10x15.3	S 24x80w/C12x20.7	S 24x80w/C12x20.7	S 24x80w/C12x20.7	S 24x106w/C12x20.7	S 24x106w/C12x20.7	S 24x106w/C12x20.7	S 24x106w/C12x20.7	52ft.	
54ft.	S 18x54.7w/C9x13.4	S 18x54.7w/C9x13.4	S 20x66w/C10x15.3	S 20x66w/C10x15.3	S 24x80w/C12x20.7	S 24x80w/C12x20.7	S 24x80w/C12x20.7	S 24x106w/C12x20.7	S 24x106w/C12x20.7	S 24x106w/C12x20.7	S 24x106w/C12x20.7	54ft.	
56ft.	S 18x54.7w/C9x13.4	S 18x54.7w/C9x13.4	S 20x66w/C10x15.3	S 20x66w/C10x15.3	S 24x80w/C12x20.7	S 24x80w/C12x20.7	S 24x80w/C12x20.7	S 24x106w/C12x20.7	S 24x106w/C12x20.7	S 24x106w/C12x20.7	S 24x106w/C12x20.7	56ft.	
58ft.	S 18x54.7w/C9x13.4	S 20x66w/C10x15.3	S 20x66w/C10x15.3	S 24x80w/C12x20.7	S 24x80w/C12x20.7	S 24x80w/C12x20.7	S 24x80w/C12x20.7	S 24x106w/C12x20.7	S 24x106w/C12x20.7	S 24x106w/C12x20.7	S 24x106w/C12x20.7	58ft.	
60ft.	S 18x54.7w/C9x13.4	S 20x66w/C10x15.3	S 24x80w/C12x20.7	S 24x80w/C12x20.7	S 24x80w/C12x20.7	S 24x80w/C12x20.7	S 24x80w/C12x20.7	S 24x106w/C12x20.7	S 24x106w/C12x20.7	S 24x106w/C12x20.7	S 24x106w/C12x20.7	60ft.	
<b>Motor Driven Crane – Center Drive</b>													
10ft.	S 7x15.3	S 7x15.3	S 10x25.4	S 10x25.4	S 12x40.8	S 12x40.8	S 18x54.7	S 18x54.7	S 20x66	S 20x66	S 20x66	10ft.	
12ft.	S 7x15.3	S 7x15.3	S 10x25.4	S 12x31.8	S 12x40.8	S 12x40.8	S 18x54.7	S 18x54.7	S 20x66	S 20x66	S 20x66	12ft.	
14ft.	S 7x15.3	S 7x15.3	S 10x25.4	S 12x31.8	S 12x40.8	S 12x40.8	S 18x54.7	S 18x54.7	S 20x66	S 20x66	S 20x66	14ft.	
16ft.	S 7x15.3	S 8x18.4	S 10x25.4	S 12x31.8	S 12x40.8	S 18x54.7	S 18x54.7	S 20x66	S 20x66	S 20x66	S 20x66	16ft.	
18ft.	S 8x18.4	S 10x25.4	S 10x25.4	S 12x31.8	S 12x40.8	S 18x54.7	S 18x54.7	S 20x66	S 20x66	S 20x66	S 20x66	18ft.	
20ft.	S 8x18.4	S 10x25.4	S 10x25.4	S 12x31.8	S 12x40.8	S 18x54.7	S 18x54.7	S 20x66	S 20x66	S 20x66	S 20x66	20ft.	
22ft.	S 10x25.4	S 10x25.4	S 10x25.4	S 12x31.8	S 12x40.8	S 18x54.7	S 18x54.7	S 20x66	S 20x66	S 20x66	S 20x66	22ft.	
24ft.	S 10x25.4	S 10x25.4	S 10x25.4	S 12x31.8	S 12x40.8	S 18x54.7	S 18x54.7	S 20x66	S 20x66	S 20x66	S 20x66	24ft.	
26ft.	S 10x25.4	S 10x25.4	S 12x31.8	S 12x40.8	S 18x54.7	S 18x54.7	S 20x66	S 20x66	S 20x66	S 20x66	S 20x66	26ft.	
28ft.	S 10x25.4	S 12x31.8	S 12x31.8	S 15x42.9	S 18x54.7	S 18x54.7	S 20x66	S 20x66	S 20x66	S 20x66	S 20x66	28ft.	
30ft.	S 12x31.8	S 12x31.8	S 15x42.9	S 15x42.9	S 20x66	S 20x66	S 20x66	S 20x66	S 20x66	S 20x66	S 20x66	30ft.	
32ft.	S 12x31.8	S 12x40.8	S 15x42.9	S 15x42.9	S 20x66	S 20x66	S 20x66	S 20x66	S 20x66	S 20x66	S 20x66	32ft.	
34ft.	S 12x31.8	S 15x42.9	S 15x42.9	S 18x54.7	S 20x66	S 20x66	S 20x66	S 20x66	S 20x66	S 20x66	S 20x66	34ft.	
36ft.	S 12x40.8	S 15x42.9	S 18x54.7	S 18x54.7	S 20x66	S 20x66	S 20x66	S 20x66	S 20x66	S 20x66	S 20x66	36ft.	
38ft.	S 15x42.9	S 15x42.9	S 18x54.7	S 18x54.7	S 20x66	S 20x66	S 20x66	S 20x66	S 20x66	S 20x66	S 20x66	38ft.	
40ft.	S 15x42.9	S 18x54.7	S 18x54.7	S 18x54.7	S 20x66	S 20x66	S 20x66	S 20x66	S 20x66	S 20x66	S 20x66	40ft.	
42ft.	S 15x42.9	S 18x54.7	S 18x54.7	S 18x54.7	S 20x66	S 20x66	S 20x66	S 20x66	S 20x66	S 20x66	S 20x66	42ft.	
44ft.	S 18x54.7	S 18x54.7	S 18x54.7	S 20x66	S 20x66	S 20x66	S 20x66	S 20x66	S 20x66	S 20x66	S 20x66	44ft.	
46ft.	S 18x54.7	S 18x54.7	S 20x66	S 20x66	S 20x66	S 20x66	S 20x66	S 20x66	S 20x66	S 20x66	S 20x66	46ft.	
48ft.	S 18x54.7	S 18x54.7	S 20x66	S 20x66	S 20x66	S 20x66	S 20x66	S 20x66	S 20x66	S 20x66	S 20x66	48ft.	
50ft.	S 18x54.7	S 18x54.7	S 20x66	S 20x66	S 20x66	S 20x66	S 20x66	S 20x66	S 20x66	S 20x66	S 20x66	50ft.	
52ft.	S 18x54.7	S 20x66	S 20x66	S 20x66	S 20x66	S 20x66	S 20x66	S 20x66	S 20x66	S 20x66	S 20x66	52ft.	
54ft.	S 18x54.7	S 20x66	S 20x66	S 20x66	S 20x66	S 20x66	S 20x66	S 20x66	S 20x66	S 20x66	S 20x66	54ft.	
56ft.	S 20x66	S 20x66	S 20x66	S 20x66	S 20x66	S 20x66	S 20x66	S 20x66	S 20x66	S 20x66	S 20x66	56ft.	
58ft.	S 20x66	S 24x80	S 24x80	S 24x80	S 24x106	S 24x106	S 24x106	S 24x106	S 24x106	S 24x106	S 24x106	58ft.	
60ft.	S 20x66	S 24x80	S 24x80	S 24x80	S 24x106	S 24x106	S 24x106	S 24x106	S 24x106	S 24x106	S 24x106	60ft.	

\*Rated load is based on maximum combined hoist and trolley weights of:  
 500 pounds for 1/2 and 1 ton hoists  
 1100 pounds for 1-1/2 and 2 ton hoists  
 1600 pounds for 3 and 4 ton hoists  
 2000 pounds for 5 and 6 ton hoists  
 3000 pounds for 7-1/2 and 8 ton hoists  
 3200 pounds for 10 ton hoists

\*\*Beam sizes listed are American Standard I-Beam and Channel sections. Use ASTM A36 grade steel, first quality, free of rust and excessive mill scale. Tabulated cross conductor system not applicable for beam less than 10' deep.

Bridge designed in accordance with CMAA Specification No. 74; Revised 1987, assuming Shaw-Boxtr trolleys.

**SIZES OF BRIDGES THAT CAN BE BUILT WITH THESE KITS (W BRIDGE BEAM)**

SPANS		(**) BEAM SIZES FOR VARIOUS SPANS										SPANS	
TO	1/2	1	1-1/2	2	3	4	5	6	7-1/2	8	10	TO	
(*) RATED LOAD IN TONS													
<b>Hand Geared Crane</b>													
10 ft.	W8x15	W8x15	W10x19	W12x22	W10x30	W14x38	W18x46	W16x50	W18x65	W18x65	W18x71	10 ft.	
12 ft.	W8x15	W8x15	W10x19	W12x22	W12x35	W18x40	W18x46	W18x55	W18x65	W18x65	W18x71	12 ft.	
14 ft.	W8x15	W8x15	W10x19	W14x26	W12x35	W18x40	W18x46	W16x57	W18x65	W18x71	W18x83	14 ft.	
16 ft.	W8x18	W8x18	W10x26	W14x26	W14x38	W16x45	W16x57	W16x57	W18x71	W18x71	W18x83	16 ft.	
18 ft.	W8x18	W8x18	W10x26	W10x30	W18x40	W16x45	W16x57	W16x57	W18x71	W18x71	W18x93	18 ft.	
20 ft.	W8x18	W8x21	W10x26	W10x30	W18x40	W18x46	W16x57	W18x60	W18x71	W18x83	W18x93	20 ft.	
22 ft.	W8x18	W10x26	W10x30	W14x34	W12x45	W16x50	W16x57	W18x65	W18x71	W18x83	W18x93	22 ft.	
24 ft.	W8x21	W10x26	W10x30	W12x35	W16x45	W16x50	W16x57	W18x65	W18x71	W18x83	W18x93	24 ft.	
26 ft.	W10x22	W10x30	W12x35	W14x38	W14x48	W14x53	W18x65	W18x65	W18x71	W18x83	W18x93	26 ft.	
28 ft.	W10x26	W10x30	W12x40	W14x38	W14x48	W16x57	W18x65	W18x71	W18x83	W18x93	W18x114	28 ft.	
30 ft.	W10x26	W14x34	W14x48	W14x43	W14x53	W18x65	W18x71	W14x82	W18x83	W18x93	W18x114	30 ft.	
32 ft.	W10x30	W12x35	W14x43	W14x48	W18x60	W16x77	W16x77	W18x83	W18x93	W24x94	W27x114	32 ft.	
34 ft.	W12x30	W14x38	W14x48	W14x48	W18x65	W16x77	W16x77	W16x89	W16x100	W27x114	W27x114	34 ft.	
36 ft.	W14x34	W12x40	W14x48	W14x53	W16x87	W16x77	W16x89	W24x94	W27x114	W27x114	W30x124	36 ft.	
38 ft.	W12x35	W14x43	W14x53	W14x61	W16x87	W16x77	W16x89	W27x102	W27x114	W30x124	W24x131	38 ft.	
40 ft.	W12x40	W14x48	W18x60	W18x65	W16x77	W18x60w/C12x20.7	W18x71w/C12x20.7	W21x83w/C12x20.7	W30x124	W30x132	W21x132	40 ft.	
42 ft.	W14x43	W14x48	W18x65	W16x87	W16x77	W18x65w/C12x20.7	W18x71w/C12x20.7	W21x83w/C12x20.7	W30x124	W30x148	W24x146	42 ft.	
44 ft.	W14x43	W14x53	W16x87	W16x87	W18x65w/C12x20.7	W18x71w/C12x20.7	W21x83w/C12x20.7	W21x83w/C12x20.7	W30x148	W30x148	W24x146	44 ft.	
46 ft.	W14x48	W18x60	W16x87	W16x77	W18x65w/C12x20.7	W21x73w/C12x20.7	W21x83w/C12x20.7	W21x83w/C12x20.7	W30x148	W30x148	W24x146	46 ft.	
48 ft.	W14x48	W18x65	W16x87	W18x60w/C12x20.7	W18x71w/C12x20.7	W21x73w/C12x20.7	W21x83w/C12x20.7	W21x83w/C12x20.7	W30x148	W27x114w/C15x33.9	W24x162	48 ft.	
50 ft.	W16x57	W18x71	W16x77	W18x60w/C12x20.7	W21x73w/C12x20.7	W21x73w/C12x20.7	W24x84w/C12x20.7	W24x84w/C12x20.7	W27x114w/C15x33.9	W27x114w/C15x33.9	W24x162	50 ft.	
52 ft.	W18x60	W21x73	W18x60w/C12x20.7	W18x65w/C12x20.7	W21x73w/C12x20.7	W21x83w/C12x20.7	W24x84w/C12x20.7	W24x84w/C12x20.7	W27x114w/C15x33.9	W27x114w/C15x33.9	W24x162	52 ft.	
54 ft.	W18x65	W21x83	W18x60w/C12x20.7	W21x73w/C12x20.7	W21x73w/C12x20.7	W24x84w/C12x20.7	W24x84w/C12x20.7	W24x84w/C12x20.7	W30x124w/C15x33.9	W30x124w/C15x33.9	W30x148w/C15x33.9	54 ft.	
56 ft.	W18x71	W21x83	W18x71w/C12x20.7	W21x73w/C12x20.7	W21x83w/C12x20.7	W24x84w/C12x20.7	W24x84w/C12x20.7	W24x84w/C12x20.7	W30x124w/C15x33.9	W30x124w/C15x33.9	W30x148w/C15x33.9	56 ft.	
58 ft.	W21x83	W18x60w/C12x20.7	W21x73w/C12x20.7	W21x73w/C12x20.7	W24x84w/C12x20.7	W24x84w/C12x20.7	W24x84w/C12x20.7	W27x102w/C15x33.9	W30x124w/C15x33.9	W30x124w/C15x33.9	W30x148w/C15x33.9	58 ft.	
60 ft.	W21x83	W18x65w/C12x20.7	W21x73w/C12x20.7	W21x73w/C12x20.7	W24x84w/C12x20.7	W24x84w/C12x20.7	W27x102w/C15x33.9	W27x102w/C15x33.9	W30x124w/C15x33.9	W30x124w/C15x33.9	W30x148w/C15x33.9	60 ft.	
<b>Motor Driven Crane – Individual Drive</b>													
10 ft.	W8x15	W8x15	W10x19	W12x22	W12x35	W18x40	W18x46	W14x53	W18x65	W18x65	W14x82	10 ft.	
12 ft.	W8x15	W8x15	W10x19	W10x26	W12x35	W18x40	W18x46	W16x57	W18x65	W18x71	W21x83	12 ft.	
14 ft.	W8x15	W8x18	W10x26	W14x26	W14x38	W10x45	W16x50	W16x57	W18x71	W18x71	W16x89	14 ft.	
16 ft.	W8x18	W8x18	W10x26	W10x30	W18x40	W16x45	W14x53	W16x57	W18x71	W18x71	W21x83	16 ft.	
18 ft.	W8x18	W8x21	W10x26	W10x30	W18x40	W18x46	W16x57	W18x65	W14x82	W21x83	W21x83	18 ft.	
20 ft.	W8x18	W8x21	W10x30	W10x30	W10x45	W12x50	W16x57	W18x65	W21x83	W21x83	W21x83	20 ft.	
22 ft.	W8x21	W10x26	W10x30	W12x35	W16x45	W16x50	W16x57	W18x65	W21x83	W21x83	W16x100	22 ft.	
24 ft.	W8x21	W10x26	W14x34	W14x38	W14x48	W14x63	W18x65	W18x71	W21x83	W21x83	W27x114	24 ft.	
26 ft.	W10x26	W10x30	W12x35	W12x40	W12x50	W16x57	W18x65	W18x71	W21x83	W21x83	W27x114	26 ft.	
28 ft.	W10x26	W10x30	W12x40	W12x40	W14x53	W18x65	W18x71	W14x82	W21x83	W21x83	W27x114	28 ft.	
30 ft.	W10x30	W12x35	W12x45	W12x45	W14x53	W16x67	W16x89	W16x89	W24x94	W16x100	W18x119	30 ft.	
32 ft.	W10x30	W14x38	W12x45	W14x48	W14x61	W16x77	W16x89	W16x89	W16x100	W27x114	W30x124	32 ft.	
34 ft.	W14x34	W12x40	W14x48	W14x53	W16x87	W16x67	W16x89	W16x89	W27x114	W27x114	W24x131	34 ft.	
36 ft.	W12x35	W12x40	W14x53	W14x61	W16x87	W16x77	W16x89	W16x100	W30x124	W30x132	W21x132	36 ft.	
38 ft.	W12x40	W12x45	W14x53	W14x61	W16x77	W16x77	W16x89	W21x83w/C12x20.7	W30x132	W30x132	W24x146	38 ft.	
40 ft.	W12x40	W14x48	W14x61	W16x67	W16x77	W16x89	W16x100	W21x83w/C12x20.7	W30x148	W30x148	W24x146	40 ft.	
42 ft.	W14x43	W16x67	W16x67	W16x67	W16x77	W18x65w/C12x20.7	W21x83w/C12x20.7	W21x83w/C12x20.7	W30x148	W30x148	W24x146	42 ft.	

**SIZES OF BRIDGES THAT CAN BE BUILT WITH THESE KITS (W BRIDGE BEAM)**

SPANS		(**) BEAM SIZES FOR VARIOUS SPANS (* RATED LOAD IN TONS)										SPANS	
TO	1/2	1	1-1/2	2	3	4	5	6	7-1/2	8	10	TO	
<b>Motor Driven Crane – Individual Drive (Continued)</b>													
44 ft.	W 14x48	W 14x63	W 16x67	W 16x77	W 18x60 w/C 12x20.7	W 18x71 w/C 12x20.7	W 21x83 w/C 12x20.7	W 21x83 w/C 12x20.7	W 30x148	W 27x114 w/C 15x33.9	W 24x146	44 ft.	
46 ft.	W 14x48	W 18x65	W 16x67	W 16x77	W 18x65 w/C 12x20.7	W 21x73 w/C 12x20.7	W 21x83 w/C 12x20.7	W 21x83 w/C 12x20.7	W 27x114 w/C 15x33.9	W 27x114 w/C 15x33.9	W 24x162	46 ft.	
48 ft.	W 14x63	W 18x71	W 16x77	W 18x60 w/C 12x20.7	W 18x71 w/C 12x20.7	W 21x73 w/C 12x20.7	W 21x83 w/C 12x20.7	W 21x83 w/C 12x20.7	W 27x114 w/C 15x33.9	W 27x114 w/C 15x33.9	W 24x162	48 ft.	
50 ft.	W 18x65	W 16x45 w/C 12x20.7	W 16x77	W 18x60 w/C 12x20.7	W 18x65 w/C 12x20.7	W 21x73 w/C 12x20.7	W 21x83 w/C 12x20.7	W 21x83 w/C 12x20.7	W 24x84 w/C 18x42.7	W 24x84 w/C 18x42.7	W 30x148 w/C 15x33.9	50 ft.	
52 ft.	W 18x71	W 16x50 w/C 12x20.7	W 18x60 w/C 12x20.7	W 18x65 w/C 12x20.7	W 21x73 w/C 12x20.7	W 21x83 w/C 12x20.7	W 21x83 w/C 12x20.7	W 21x83 w/C 12x20.7	W 27x114 w/C 15x33.9	W 27x114 w/C 15x33.9	W 30x148 w/C 15x33.9	52 ft.	
54 ft.	W 16x45 w/C 12x20.7	W 16x57 w/C 12x20.7	W 18x60 w/C 12x20.7	W 21x73 w/C 12x20.7	W 21x73 w/C 12x20.7	W 24x84 w/C 12x20.7	W 24x84 w/C 12x20.7	W 24x84 w/C 12x20.7	W 30x124 w/C 15x33.9	W 30x124 w/C 15x33.9	W 30x148 w/C 15x33.9	54 ft.	
56 ft.	W 16x45 w/C 12x20.7	W 18x60 w/C 12x20.7	W 18x71 w/C 12x20.7	W 18x60 w/C 12x20.7	W 21x73 w/C 12x20.7	W 21x83 w/C 12x20.7	W 21x83 w/C 12x20.7	W 21x83 w/C 12x20.7	W 30x124 w/C 15x33.9	W 30x124 w/C 15x33.9	W 30x148 w/C 15x33.9	56 ft.	
58 ft.	W 16x57 w/C 12x20.7	W 18x60 w/C 12x20.7	W 21x73 w/C 12x20.7	W 21x73 w/C 12x20.7	W 21x73 w/C 12x20.7	W 24x84 w/C 12x20.7	W 24x84 w/C 12x20.7	W 24x84 w/C 12x20.7	W 30x132 w/C 15x33.9	W 30x132 w/C 15x33.9	W 30x148 w/C 15x33.9	58 ft.	
60 ft.	W 18x60 w/C 12x20.7	W 18x65 w/C 12x20.7	W 21x73 w/C 12x20.7	W 21x73 w/C 12x20.7	W 21x73 w/C 12x20.7	W 24x84 w/C 12x20.7	W 24x84 w/C 12x20.7	W 24x84 w/C 12x20.7	W 30x132 w/C 15x33.9	W 30x132 w/C 15x33.9	W 30x148 w/C 15x33.9	60 ft.	
<b>Motor Driven Crane – Center Drive</b>													
10 ft.	W 8x15	W 8x15	W 10x19	W 12x22	W 12x35	W 18x40	W 18x46	W 14x53	W 18x65	W 18x65	W 14x82	10 ft.	
12 ft.	W 8x15	W 8x15	W 12x22	W 10x26	W 12x35	W 10x45	W 18x46	W 16x57	W 18x65	W 18x71	W 21x83	12 ft.	
14 ft.	W 8x15	W 10x17	W 12x22	W 14x26	W 14x38	W 10x45	W 16x57	W 16x57	W 18x71	W 18x71	W 16x89	14 ft.	
16 ft.	W 8x15	W 8x18	W 12x22	W 10x30	W 18x40	W 16x45	W 18x55	W 16x57	W 18x71	W 18x71	W 21x83	16 ft.	
18 ft.	W 8x15	W 10x19	W 10x26	W 10x30	W 18x40	W 18x46	W 16x57	W 18x65	W 14x82	W 21x83	W 21x83	18 ft.	
20 ft.	W 10x15	W 10x19	W 10x26	W 10x30	W 10x45	W 18x46	W 16x57	W 18x65	W 21x83	W 21x83	W 21x83	20 ft.	
22 ft.	W 10x15	W 10x19	W 10x26	W 14x34	W 18x45	W 16x50	W 16x57	W 18x65	W 21x83	W 21x83	W 27x114	22 ft.	
24 ft.	W 12x16	W 10x22	W 12x30	W 12x35	W 18x46	W 14x63	W 18x65	W 18x71	W 21x83	W 21x83	W 27x114	24 ft.	
26 ft.	W 12x16	W 12x22	W 16x31	W 12x35	W 18x46	W 18x55	W 18x65	W 18x71	W 21x83	W 21x83	W 27x114	26 ft.	
28 ft.	W 12x19	W 12x26	W 16x31	W 14x38	W 16x50	W 16x57	W 18x65	W 14x82	W 21x83	W 21x83	W 27x114	28 ft.	
30 ft.	W 12x19	W 12x26	W 14x34	W 14x38	W 18x50	W 16x57	W 18x71	W 21x83	W 21x83	W 21x83	W 18x119	30 ft.	
32 ft.	W 12x22	W 14x26	W 16x36	W 16x40	W 18x55	W 18x60	W 18x71	W 21x83	W 16x100	W 27x114	W 30x124	32 ft.	
34 ft.	W 14x22	W 16x26	W 16x40	W 18x40	W 18x55	W 18x65	W 18x71	W 21x83	W 27x114	W 27x114	W 21x132	34 ft.	
36 ft.	W 14x26	W 16x31	W 16x40	W 18x40	W 21x57	W 18x65	W 21x83	W 21x83	W 27x114	W 27x114	W 21x132	36 ft.	
38 ft.	W 14x26	W 16x31	W 16x40	W 18x46	W 21x57	W 18x65	W 21x83	W 21x83	W 27x114	W 27x114	W 21x132	38 ft.	
40 ft.	W 16x26	W 18x35	W 18x40	W 18x46	W 18x60	W 21x68	W 21x83	W 21x83	W 27x114	W 27x114	W 30x132	40 ft.	
42 ft.	W 16x31	W 18x35	W 21x44	W 18x50	W 21x68	W 21x73	W 21x83	W 21x83	W 27x114	W 27x114	W 33x141	42 ft.	
44 ft.	W 16x31	W 18x35	W 18x50	W 21x50	W 21x68	W 21x73	W 21x83	W 24x94	W 30x124	W 30x124	W 24x146	44 ft.	
46 ft.	W 18x35	W 18x40	W 21x50	W 21x55	W 21x68	W 24x76	W 21x83	W 24x94	W 30x124	W 30x124	W 24x146	46 ft.	
48 ft.	W 18x35	W 21x44	W 21x50	W 21x57	W 21x73	W 24x84	W 24x94	W 27x102	W 30x124	W 30x132	W 30x148	48 ft.	
50 ft.	W 18x40	W 21x44	W 24x55	W 21x62	W 24x76	W 24x84	W 24x94	W 27x114	W 30x132	W 30x132	W 30x148	50 ft.	
52 ft.	W 18x40	W 21x44	W 24x55	W 24x62	W 24x76	W 24x84	W 24x94	W 27x114	W 30x132	W 30x132	W 30x148	52 ft.	
54 ft.	W 21x44	W 21x50	W 24x55	W 24x62	W 24x76	W 24x84	W 27x102	W 27x114	W 30x132	W 30x132	W 30x148	54 ft.	
56 ft.	W 21x44	W 24x55	W 24x68	W 24x68	W 24x84	W 24x94	W 27x102	W 27x114	W 30x132	W 30x148	W 30x148	56 ft.	
58 ft.	W 21x44	W 24x55	W 24x68	W 24x68	W 27x84	W 27x94	W 27x102	W 27x114	W 30x148	W 30x148	W 33x169	58 ft.	
60 ft.	W 21x50	W 24x55	W 24x68	W 24x76	W 27x84	W 27x94	W 27x114	W 30x124	W 30x148	W 30x148	W 33x169	60 ft.	

\*Rated load is based on maximum combined hoist and trolley weights of:  
 500 pounds for 1/2 and 1 ton hoists  
 1100 pounds for 1-1/2 and 2 ton hoists  
 1600 pounds for 3 and 4 ton hoists  
 2000 pounds for 5 and 6 ton hoists  
 3000 pounds for 7-1/2 and 8 ton hoists  
 3200 pounds for 10 ton hoists

\*\*Beams listed are American Standard Wide Flange Beams and Channels sections. Use ASTM A36 grade steel, first quality, free of rust and excessive mill scale. Tabulated cross conductor system not applicable for beam less than 10" deep.  
 Bridge designed in accordance with CMAA Specification No. 74, Revised 1987, assuming Shaw-Box trolleys.



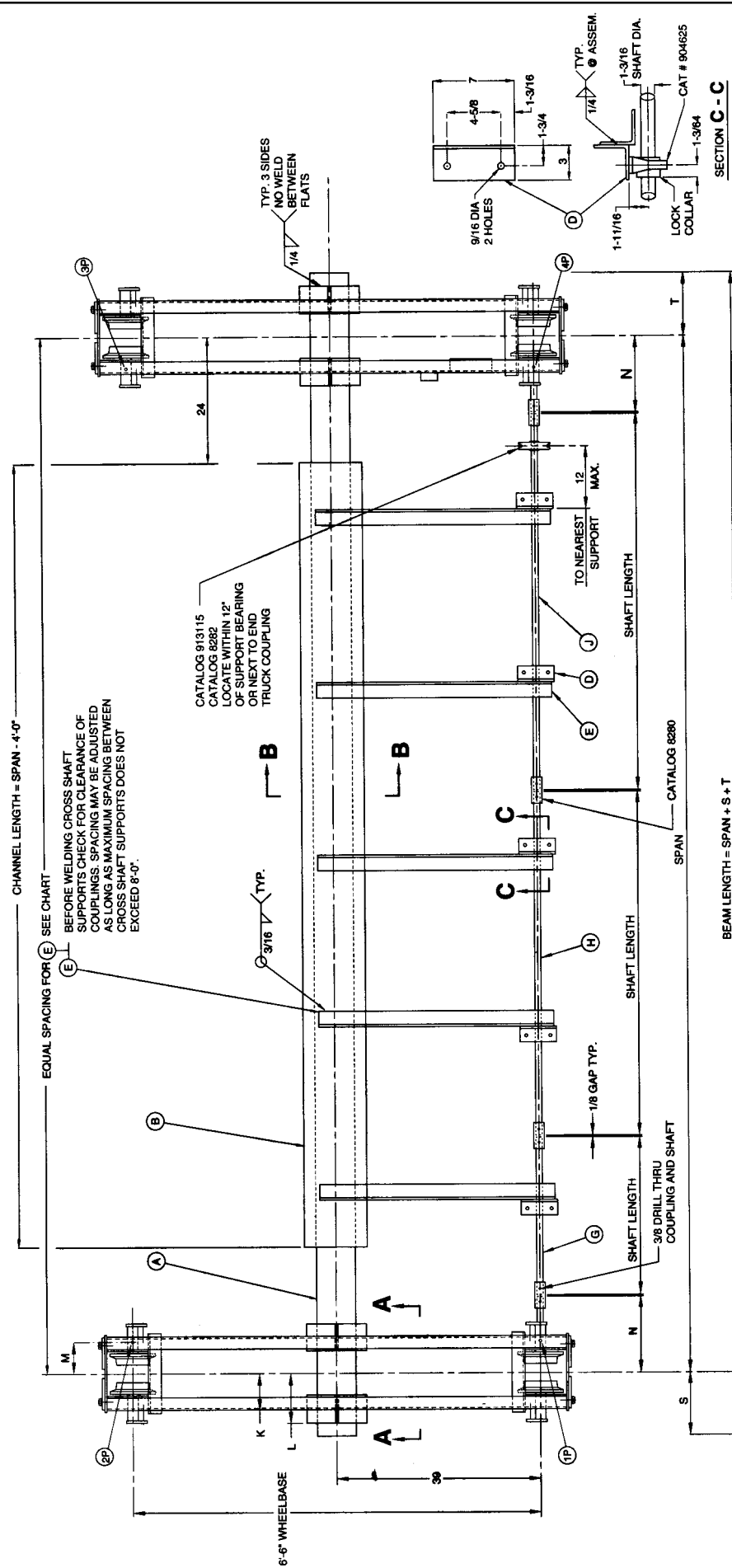

ITEM	12"	22"	28"	36"	42"	52"	60"
SPACES	2	3	4	5	6	7	8
D & E	1	2	3	4	5	6	7
G	1	2	2	2	2	3	3
LENGTH OF G	SPAN - 2N - 1/4		SPAN - 2N - 3/8		SPAN - 2N - 1/2		SPAN - 3

ITEM	QUANTITY	DESCRIPTION
C	4	ANGLE SEE CHART
D	SEE CHART	ANGLE 3 X 3 X 1/4 X 7' LG
E	SEE CHART	ANGLE 3 X 3 X 1/4 X 45' LG

WHEEL DIAMETER	END TRUCK CATALOG NO.	RUNWAY FLANGE ADJ.	K	L	M	N	P*	S & T STANDARD W/ TRANSFER
6-1/2	913101	4-5/8	6	7-1/16	9-1/2	6	15-3/4	12
	913101M1	6-1/8	6	8-5/16	10-3/4	7	1-1/8	24
	913101W2	8-5/8	7	9-9/16	12	8	13-1/4	
8	913108	5-7/8	7	8-1/8	11-3/8	6	15-3/4	14
	913108M1	7-1/8	8	9-1/2	12-5/8	7	1-1/2	24
	913108W2	9-5/8	12	10-5/8	13-7/8	8	18-1/4	

BRIDGE BEAM FLANGE WIDTH	ANGLE SIZE
3-5/8 - 4	3-1/2 x 3 x 3/8
4-1/4 - 6-1/4	5 x 3 x 3/8
6-1/2 - 8-1/4	6 x 4 x 3/8
8-1/2 - 10-1/2	7 x 4 x 3/8
10-5/8 - 13	8 x 4 x 1/2

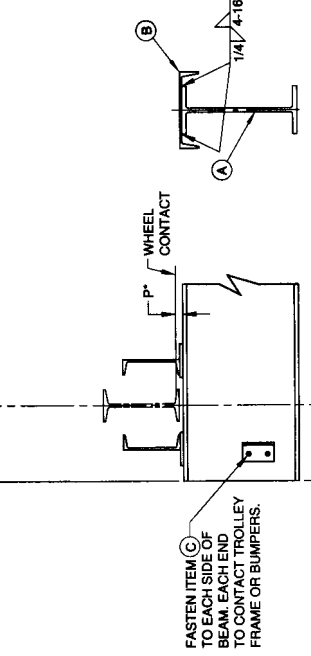

# HAND GEARED - BRIDGE ASSEMBLY

\* CLEARANCE = P - RUNWAY BEAM FLANGE THICKNESS

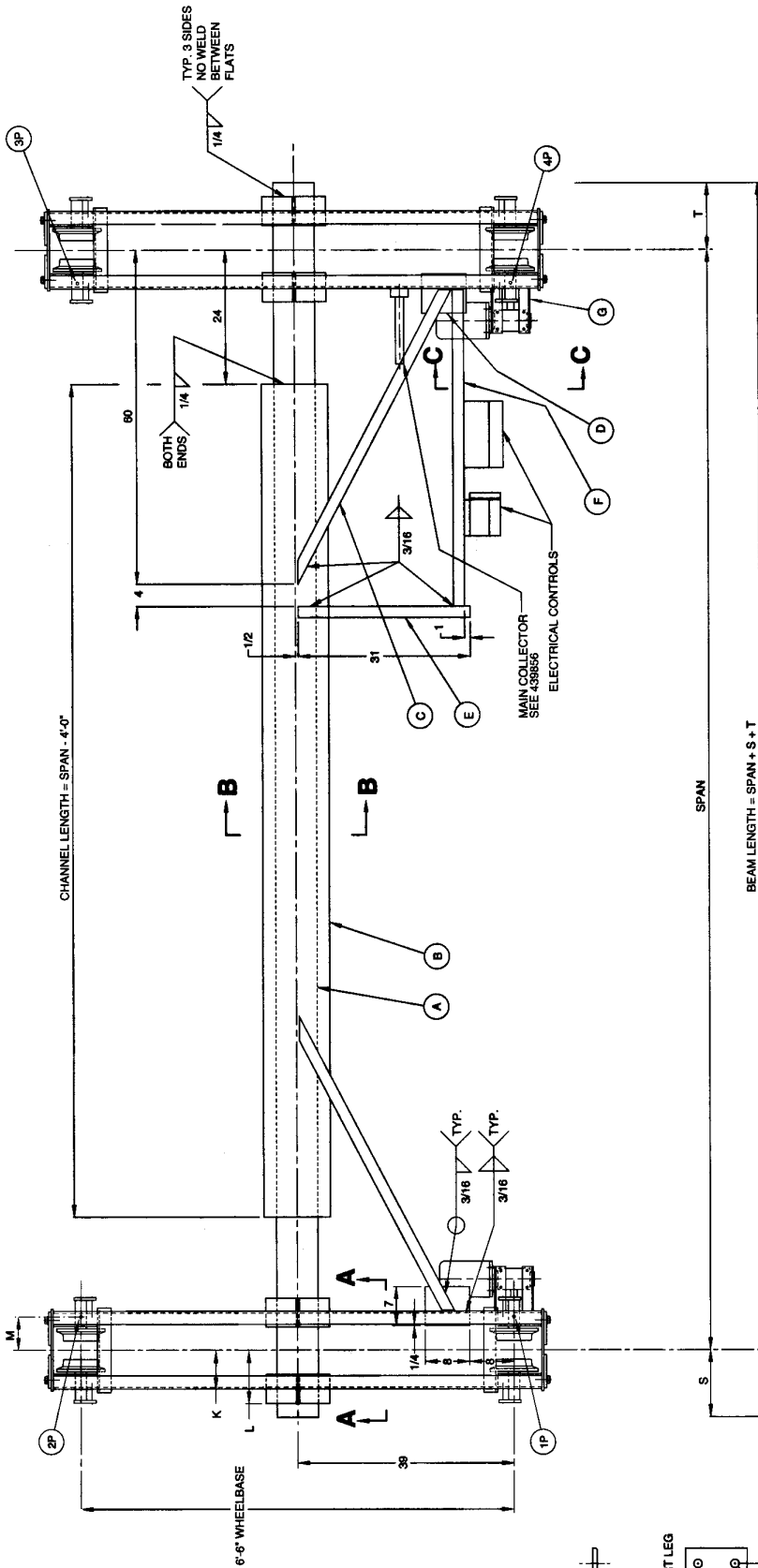

WHEEL DIAMETER	END TRUCK CATALOG NO.	RUNWAY FLANGE ADJ.	K	L	M	N	P	Q	S & T STANDARD	S & T W/ TRANSFER
6-1/2	913101	4-5/8 - 6	7-1/16	9-1/2	6	1-1/8	4-1/4	5-3/4	12	24
	913101W1	6-1/8 - 8-1/2	8-5/16	10-3/4	7					
	913101W2	8-5/8 - 11	9-9/16	12	8					
	913106	5 - 7	8-1/8	11-3/8	6					
	913106W1	7-1/8 - 9-1/2	9-3/8	12-5/8	7-1/4	1-1/2	3-1/8	4-5/8	14	24
8	913106W2	9-5/8 - 12	10-5/8	13-7/8	8-1/2					

\* CLEARANCE = N - RUNWAY BEAM FLANGE THICKNESS

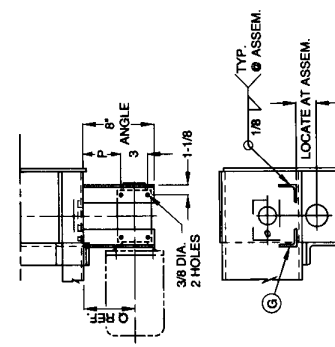

VIEW C-C

ITEM	QUANTITY	DESCRIPTION
C	2	2 x 2 x 3/16 SQ TUBING x 60" LG
D	2	1/4 x 7 x 8 PLATE
E	1	2 x 2 x 3/16 SQ TUBING x 31" LG
F	1	2 x 2 x 3/16 SQ TUBING x 95" LG
G	4	2 x 2 x 1/4 ANGLE x 8" LG
H	4	ANGLE (SEE CHART)

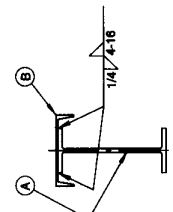

SECTION B-B

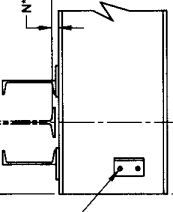

SECTION A-A

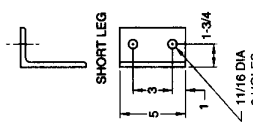

TROLLEY STOP ITEM (H)	BRIDGE BEAM FLANGE WIDTH	ANGLE SIZE
3-5/8 - 4	3-1/2 x 3 x 3/8	3-1/2 x 3 x 3/8
4-1/4 - 6-1/4	5 x 3 x 3/8	5 x 3 x 3/8
6-1/2 - 8-1/4	6 x 4 x 3/8	6 x 4 x 3/8
8-1/2 - 10-1/2	7 x 4 x 3/8	7 x 4 x 3/8
10-5/8 - 13	8 x 4 x 1/2	8 x 4 x 1/2

FASTEN ITEM (H) TO EACH SIDE OF BEAM EACH END TO CONTACT TROLLEY FRAME OR BUMPERS.

INDIVIDUAL DRIVE - BRIDGE ASSEMBLY

ITEM	QUANTITY	DESCRIPTION
B	1	SEE CHART
C	SEE CHART	ANGLE 2" x 2" x 1/4" x 48" LG
D	SEE CHART	ANGLE 3" x 3" x 1/4" x 7" LG
E	SEE CHART	ANGLE 2" x 2" x 1/4" x SEE CHART LENGTH
F	2	PLATE 1/4" x 6" x 6"
G	1	SHAFT 1-3/16 DIA x 48" LG
H	1	CHANNEL 7" x 9.8# x 45-1/2" LG
J	1	ANGLE 3" x 3" x 5" LG
K	2	ANGLE SEE CHART SIZE x 5" LG
L	4	SHAFT 1-3/16" DIA x SEE CHART
M	SEE CHART	

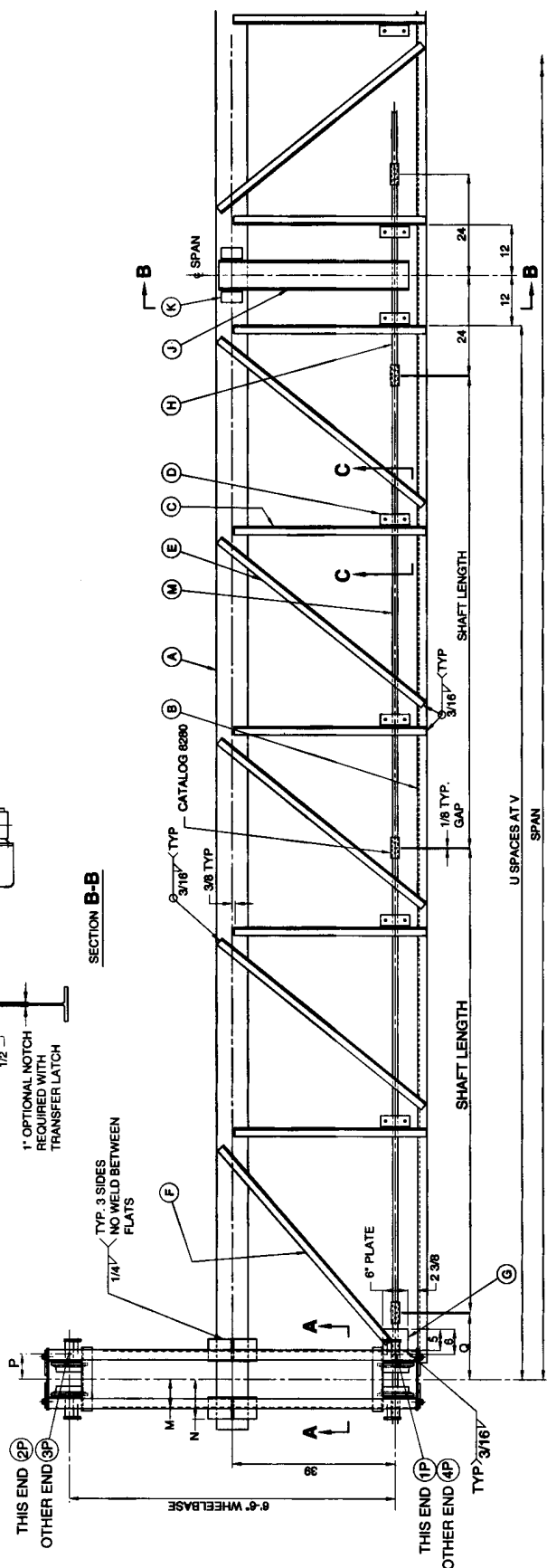
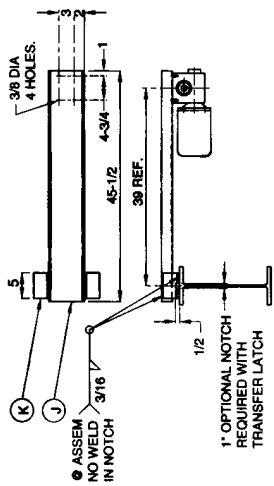

ITEM	QUANTITY FOR SPANS THRU
U	2
V	2
W	2
X	2
Y	2
Z	2

$V = \frac{\text{SPAN} \cdot Z \cdot 3}{2 \cdot U}$   
 LENGTH OF E =  $[(V \cdot 3)^2 + (45)^2]^{1/2}$   
 LENGTH OF F =  $[(V \cdot 14)^2 + (39)^2]^{1/2}$   
 LENGTH OF M:  
 THRU 42" =  $\frac{\text{SPAN} \cdot 2 \cdot Q \cdot 4 - 0 \cdot 1/2'}{2}$   
 OVER 42" =  $\frac{\text{SPAN} \cdot 2 \cdot Q \cdot 4 - 0 \cdot 3/4'}{4}$

ITEM	QTY FOR SPANS THRU
2A	2
3B	2
6A	2
6B	2
6C	2
6D	2
6E	2
6F	2
6G	2
6H	2
6I	2
6J	2
6K	2
6L	2
6M	2

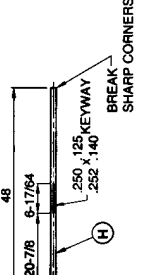

WHEEL DIAMETER	END TRUCK CATALOG NO.	RUNWAY FLANGE ADJ.	M	N	P	Q	R*	S & T STANDARD	S & T W/ TRANSFER
6-1/2	913101	4-5/8 - 6	7-7/16	9-1/2	6	15-3/4	1-7/8	12	24
	913101W1	6-1/8 - 6-1/2	8-5/16	10-3/4	7	17	1-7/8	12	24
	913101W2	8-5/8 - 11	9-9/16	12	8	18-1/4	1-7/8	12	24
	913106	5-7	8-1/8	11-3/8	6	15-3/4	1-1/2	14	24
	913106W1	7-1/8 - 9-1/2	9-3/8	12-5/8	7-1/4	17	1-1/2	14	24
	913106W2	9-5/8 - 12	10-5/8	13-7/8	8-1/2	18-1/4	1-1/2	14	24

\* CLEARANCE = R - RUNWAY BEAM FLANGE THICKNESS

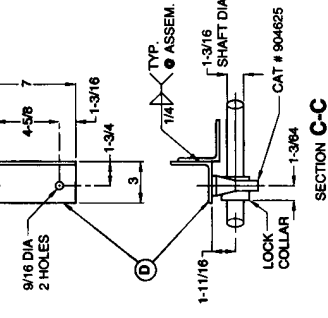
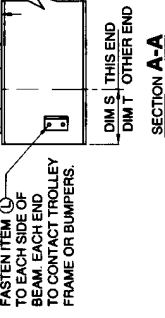

BRIDGE BEAM FLANGE WIDTH	ANGLE SIZE
3-5/8 - 4	3-1/2 x 3 x 3/8
4-1/4 - 6-1/4	5 x 3 x 3/8
6-1/2 - 8-1/4	6 x 4 x 3/8
8-1/2 - 10-1/2	7 x 4 x 3/8
10-5/8 - 13	8 x 4 x 1/2

# CENTER DRIVE - BRIDGE ASSEMBLY

# TO BUILD UNDERHUNG CRANE BRIDGES

THE INFORMATION CONTAINED IN THIS MANUAL IS FOR INFORMATIONAL PURPOSES ONLY AND COLUMBUS MCKINNON CORPORATION DOES NOT WARRANT OR OTHERWISE GUARANTEE (IMPLIEDLY OR EXPRESSLY) ANYTHING OTHER THAN THE COMPONENTS THAT COLUMBUS MCKINNON CORPORATION MANUFACTURES AND ASSUMES NO LEGAL RESPONSIBILITY (INCLUDING, BUT NOT LIMITED TO CONSEQUENTIAL DAMAGES) FOR INFORMATION CONTAINED IN THIS MANUAL.

## GENERAL

The assembly and manufacturing instructions including the parts lists detailed in this manual are for use in conjunction with the manufacturers components identified by Catalog numbers listed under the THREE types of drives covered by this manual and as shown on pages 2 and 3.

The crane builder must check for compliance with all local, state and national codes. On a hand powered crane with an electric hoist, a fused safety disconnect switch should be provided mounted on the bridge near the main collectors. Crane wiring should be done by a licensed electrician and be in accordance with the National Electric Code.

The crane bridges described in this manual are intended for normal indoor service. Bridges to be used for outdoor or unusual service require special consideration.

This manual illustrates specific configurations for the range of coverage shown, specifically for 10 ft. thru 60 ft. span and up to and including 10 ton capacity. Minor deviations to the configurations shown (such as shaft bearing spacing, shaft lengths, etc.) may be made providing that any changes and/or alterations to those shown, be performed only by a properly qualified person. **COLUMBUS MCKINNON CORPORATION** accepts no responsibility for any altered bridge configurations.

The proper catalog numbers must be ordered to build the required crane. Five catalog numbers are required to build a hand geared crane. Five catalog numbers are required for an individual drive crane and seven catalog numbers are required for the center drive crane. Additional options for additional equipment are available and listed by catalog numbers on pages 2 and 3.

Material listed by catalog numbers on pages 2 and 3 are applicable only to crane configurations outlined in this manual, specifically limited to a maximum rated load of 10 ton and a maximum span of 60 ft.

Cataloged end trucks listed on page 2 will accommodate the beam sizes listed below. The crane builder must determine that the runway beam flange selected will support the resulting maximum wheel load.

The 5 ton end trucks have 6-1/2" diameter solid steel wheels (maximum allowable load is 9000 pounds per pair of wheels). 10 ton end trucks have 8" diameter solid steel

wheels (maximum allowable load is 18000 pounds per pair of wheels).

Rated Load (thru)	Minimum Runway Beam Flange Width	Maximum Runway Beam Flange Width	Minimum Beam	Maximum Flange Thickness
5 Ton	4-5/8	11	S 10 x 25.4	1"
10 Ton	5	12	S 12 x 31.8	1-3/8"

**RUNWAYS:** Runway beams must be properly designed to support bridge, hoist, trolley and rated load. Runway beams must be level and parallel within  $\pm 1/8"$ . Runway stops must be positioned to contact both ends of the crane simultaneously.

## MATERIAL TO BE PURCHASED LOCALLY TO COMPLETE A CRANE BRIDGE

**STRUCTURAL STEEL:** All structural steel should be first quality, free from rust and excessive mill scale, and conform to ASTM A 36.

For the complete drawing identifying all dimensions, material sizes, location of cross shafting, brackets, etc. refer to the following chart:

BRIDGE ASSEMBLY	PAGE
Hand Geared	8
Individual Drive	9
Center Drive	10

**BRIDGE BEAMS:** For each capacity, span and type of bridge drive select from tables shown on pages 4, 5, 6 & 7.

The I-beam which is selected to be used for the bridge girder must be straight with flanges parallel to each other and flanges 90 degrees to the web. See figure A below.

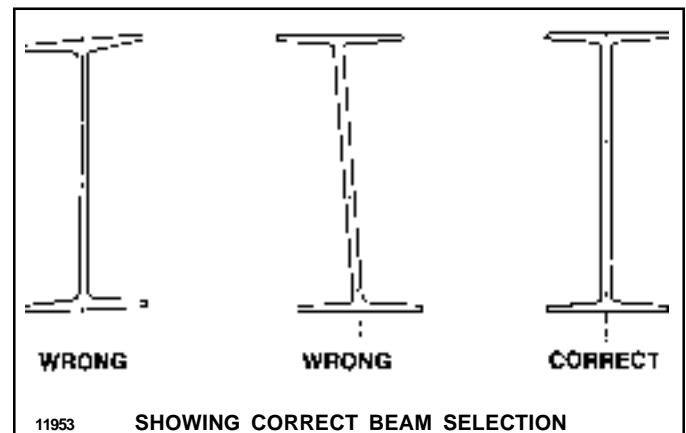

Figure A

**NOTICE**

- A. All of the tables used in selection of structural steel beams have been produced by our engineering department using well established design guides for this type of crane bridge. IT IS IMPORTANT THAT ALL INSTRUCTIONS BE FOLLOWED AND THAT RECOMMENDED COMPONENT APPLICATION LIMITS NOT BE EXCEEDED.
- B. Assembly of beam and channel requires welding. IT IS EXTREMELY IMPORTANT TO THE SAFETY OF THIS BRIDGE THAT THIS WELDING BE DONE BY A COMPETENT WELL TRAINED WELDER. It is our strong recommendation that the welder used in this construction be qualified as prescribed by the American Welding Society (AWS) Specification for Welding Industrial and Mill Cranes D14.1 - latest issue.

with the weld information given, starting at one end, staggering weld from side-to-side, proceeding to the opposite end without interruption. It is important to stagger weld from side-to-side in order to retain beam straightness. After welding, draw a taut string from end to end of beam as shown. Beam should either be parallel to string or have some camber. Camber should not exceed 1/800 of span.

**CROSS SHAFT:** For hand geared and center drive cranes, cross shafts are required. The cross shafts are to be 1-3/16" diameter AISI 1018 cold drawn steel, with standard mill tolerance of +.000", -.002". For shaft lengths, refer to the appropriate Bridge Assembly Drawing. (Builder must check that cross shaft couplings clear cross shaft support bearings.)

**TRANSFER LATCH:** For cranes to be equipped with a transfer latch, all angles welded to the top flange of the girder must be notched as shown in Figure C. Also the "S" and "T" dimensions should be determined from the appropriate Bridge Assembly Drawing.

**FABRICATION OF GIRDER FOR BRIDGE BEAM WITH CAPPING CHANNEL**

Refer to Figure B. Place channel on supports as shown in Step I. The I-beam is sighted for camber and placed with camber in direction shown in Step II. Weld one end of channel to the I-beam. Clamp, with "C" clamps, the channel to the I-beam flange – provide sufficient "C" clamps so as to hold channel in contact with the I-beam. Weld in accordance

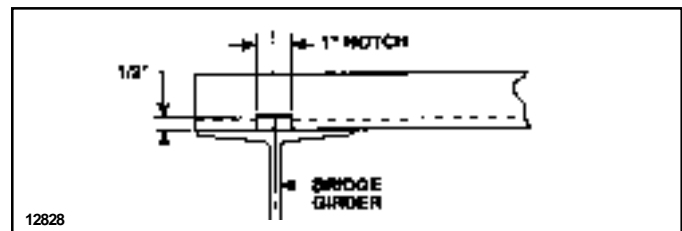
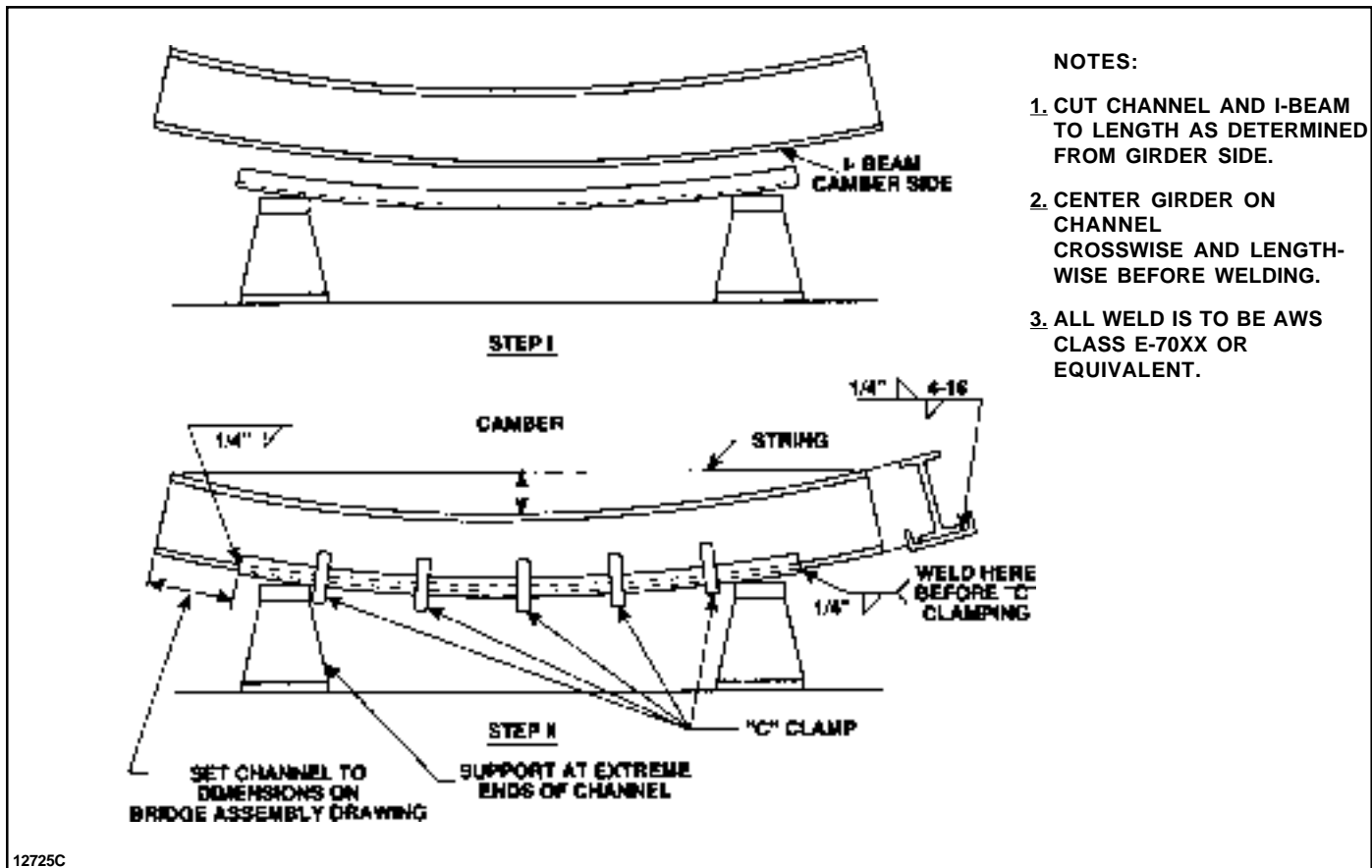

Figure C



**NOTES:**

1. CUT CHANNEL AND I-BEAM TO LENGTH AS DETERMINED FROM GIRDER SIDE.
2. CENTER GIRDER ON CHANNEL CROSSWISE AND LENGTHWISE BEFORE WELDING.
3. ALL WELD IS TO BE AWS CLASS E-70XX OR EQUIVALENT.

Figure B



## WARNING

Trolley stops (clip angles) must be installed on both ends of the bridge beam to prevent hoist trolley from running off the end of the beam, which could result in injury to the operator and others and damage to the load and other property.

### ASSEMBLING BRIDGE GIRDER TO END TRUCKS

1. Refer to Figure D below.
2. Support bridge girder on level supports with camber side (channel side) up.
3. Layout and scribe the center line (over the web) of the flange at each end of the girder.
4. Layout and scribe span line (90° to web) on top flange of girder. Check "S" and "T" dimensions to span line.
5. Locate and scribe lines locating the center of the truck.
6. Place trucks in position on the girder. Line up girder and truck centerlines. Line up truck on girder span line.
7. Square trucks on top of girder and securely clamp in place. To check the distance between trucks the distances between points 1P and 4P and between 2P and 3P should equal the span minus 2x"M". Refer to the Bridge Assembly drawing for the "M" dimension.
8. To check squareness, use a spring scale on the end of the tape and measure from point 1P to 3P and from 2P to 4P with the same force on the scale. These dimensions should be within 1/32" of each other.

9. Check to see that trucks are level and that the wheels are parallel to the bottom flange of the girder. Shim top flange to bottom of truck girder seat plates if required as shown in Figure D.

10. After all checks are completed, weld trucks to girder.

### INSTRUCTIONS FOR ASSEMBLING HAND GEARED CRANE BRIDGE

1. Refer to Bridge Assembly drawing page 8.
2. Prepare bridge girder I-beam with capping channel if required (see Figure B, page 12).
3. Follow instructions for assembling bridge girder to end trucks.
4. Bolt cross shaft pillow blocks to short support angles Item (D).
5. Locate and clamp cross shaft support angles (Item (E) & (F)) to the girder.
6. Place the proper number of pillow blocks (with support angles) and couplings on each shaft section. Check to insure that the flange of Item (D) is in correct relationship for later welding to Items (E) or (F). Notice that the separate bearing locking collar has a counterbore on one side. This counterbore fits over the protruding inner race. Place locking collar on shaft accordingly. Place hand chain wheel and guide on the appropriate shaft section and position within 12" of a bearing support.
7. Set shafting in place, align pillow blocks to the cross shaft support angles and clamp in place.
8. Check horizontal and vertical alignment of the cross shaft by using a taut line. Weld cross shaft support angles

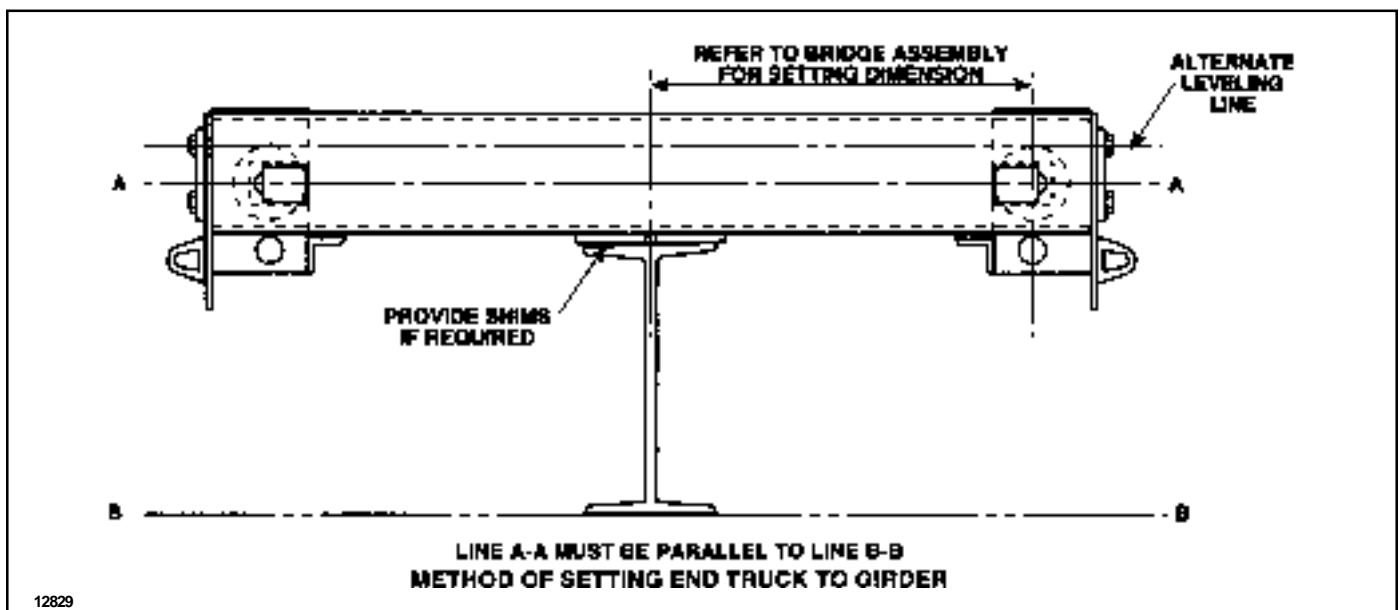

Figure D

to the girder and pillow block support angles to the cross shaft support angles when alignment is complete.

9. Set space between cross shafts to 1/8". Position couplings and drill 3/8" diameter holes thru the shaft and couplings using the holes in one side of the coupling as a guide. (Coupling has a pre-drilled 11/32" hole through one side only.) Shaft and coupling is then secured by hex head bolts with lockwashers and nuts (see Figure 3).

10. Slide bearing locking collars in place next to pillow block. Make certain that the counter bore in collar is fitted over the extended inner race of the bearing. Fasten to shaft with set screw in locking collar.

11. Locate and fasten trolley stop angles (Item ©) to the ends of the girder by drilling 11/16" diameter holes through the web of the girder and fastening with 5/8" diameter bolts and stop nuts.

### **INSTRUCTIONS FOR ASSEMBLING INDIVIDUAL DRIVE MOTOR DRIVEN CRANE BRIDGE**

1. Refer to the Bridge Assembly drawing page 9.
2. Prepare bridge girder I-beam with capping channel if required (see Figure B, page 12).
3. Follow instructions for assembling bridge girder to end trucks, as outlined on page 13.
4. Locate and weld plate (Item ①) to underside of end truck as shown.
5. Locate and weld diagonal tube (Item ©) to top of girder and plate ① as shown.
6. Weld tubes (Items ② & ③) to top of girder and plate ① as shown.
7. Bolt the motor to the gear reducer with four hex head bolts and lockwashers. Bolt the support angles (Item ©) to the gear reducer using four hex head bolts and lock washers. See view C-C of the Bridge Assembly page 9.
8. Place key in truck drive shaft, slide gear reducer into place over drive shaft and weld support angles (Item ©) to side of truck as shown.
9. It is suggested that the electrical enclosure and fused disconnect switch be mounted using tube (Item ④) as a support. Suggested arrangement is shown on the Bridge Assembly drawing.
10. If ballast resistors (optional) are furnished, four holes are provided in the side of the electrical enclosure for mounting.
11. Locate and fasten trolley stop angles (Item ⑤) to the ends of the girder by drilling 11/16" diameter holes through the web of the girder and fastening with 5/8" diameter bolts

and stop nuts.

### **INSTRUCTIONS FOR ASSEMBLING CENTER DRIVE MOTOR DRIVEN CRANE BRIDGE**

1. Refer to the Bridge Assembly drawing page 10.
2. Follow instructions for assembling bridge girder to end trucks, as outlined on page 13.
3. Clamp channel auxiliary girder to end plate of end trucks. Locate as shown on Bridge Assembly drawing. Level top of channel with top flange of bridge girder.
4. Locate and weld plate (Item ⑥) to underside of truck channel as shown on Bridge Assembly.
5. Position and clamp cross shaft angles (Item ©) to bridge girder and auxiliary girder as shown on Bridge Assembly.
6. Bolt cross shaft pillow blocks to short support angles (Item ⑦).
7. Place the proper number of pillow blocks (with support angles) and couplings on each shaft section. Check to insure that the flange of Item ⑧ is in correct relationship with the cross shaft support angles (Item ©). Notice that the separate bearing locking collar has a counterbore on one side. This counterbore fits over the protruding inner race of the pillow block bearing. Place locking collar on shaft accordingly.
8. Set shafting in place, align pillow blocks to the cross shaft support angles and clamp in place.
9. Weld the cross shaft support angles to the bridge and auxiliary girder.
10. Bolt the motor to the gear reducer with four hex head bolts and lockwashers. Bolt the gear reducer to the drive support channel (Item ⑨) as shown on the Bridge Assembly drawing.
11. Place key in drive shaft (Item ⑩) and slide drive shaft into hollow shaft of the gear reducer. Position drive shaft to extend the same distance either side of the reducer and tighten set screws that hold shaft in place.
12. Locate and clamp center drive support channel (Item ⑪) to the bridge girder.
13. Check horizontal and vertical alignment of the cross shaft by using a taut line. Weld pillow block support angles to the cross shaft support angles when alignment is complete.
14. Weld center drive support channel to top of bridge girder.
15. Set space between cross shafts to 1/8". Position couplings and drill 3/8" diameter holes through the shaft and coupling using the holes in the coupling as a guide. (Coupling has a pre-drilled 11/32" diameter hole through

one side only.) Shaft and coupling is then secured by hex head bolts with lockwashers and nuts (see Figure 3).

16. Slide bearing locking collars in place next to pillow blocks. Make sure that the counterbore in collar is fitted over the extended inner race of the bearing. Fasten to shaft with set screw in locking collar.

17. Locate, place and weld diagonal horizontal truss angles (Items (E) & (F)).

18. It is suggested that the electrical enclosure and fused disconnect switch be located off the channel auxiliary girder, and be supported by it.

19. If ballast resistors (optional) are furnished, four holes are provided in the side of the electrical enclosure for mounting.

20. Locate and fasten trolley stop angles (Item (L)) to the ends of the girder by drilling 11/16" diameter holes through the web of the girder and fastening with 5/8" diameter bolts and stop nuts.

### PAINTING

After all welding is completed and prior to installing the cross conductors, wire brush all steel and remove all scale weld splatter, flux and any other foreign matter. Grease spots are to be cleaned using commercially available solvent. Wash with clear water an area six inches either side of all welds to remove flux residue.

The electrical panel must be closed, and areas such as the switch handle, Off-On identification, wheel gear and pinion, any nameplate, etc., must be masked prior to painting.

Any national brand zinc-rich, chromate primer can be used and applied according to the manufacturers directions. Final coat is recommended to be high gloss enamel, especially suited for steel surfaces and as recommended by any national brand paint manufacturer. Application must be in accordance with manufacturers' recommendations.

### MARKING

Codes require that the capacity of the bridge be shown on both sides of the crane, legible from the floor. Normal practice for marking is to use capacity in tons. For example: 1 TON, 2 TON, etc. Stencil forms are readily available that may be used with brush on or spray-can paint. Commercially available block letters and numerals with adhesive backing could also be used. Selection of size should be such that the sign can be easily read from the operating floor.

The builder's name shall also be placed on the crane in a prominent location along with a serial number or other means of easy identification.

### NOTICE

The crane builder and user are responsible for

marking crane and also to check for compliance with local, state and national codes.

### CROSS CONDUCTOR ASSEMBLY

Refer to Cross Conductor Arrangement drawing page 16.

A cross conductor system is a means of providing electric current from the main conductors to the moving hoist-trolley.

The type of cross conductor system is a guarded type. Shown on page 16, is a typical type using a figure (8) bar with an insulating cover. Spacing shown does not insure that such spacing will be correct for all hoist-trolley combinations. Responsibility for checking all clearances rests with the builder. The builder is also CAUTIONED to consult with the conductor manufacturer on special applications involving transfer of hoist-trolley with the use of a transfer latch, and also for special conditions involving unusual temperature and environment.

Care should be exercised in balancing the number of conductors on either side of the bridge beam. (This is especially critical with a light capacity hoist-trolley unit.) Control circuit collectors should be 30 Amp. Catalog #904101.

The main power collectors can be 30 Amp. Catalog #904101 if the hoist motor is 10 Horsepower or less. If the hoist motor exceeds 10 Horsepower then the 100 Amp. Catalog #904110 collector must be used.

### MAIN COLLECTOR ASSEMBLY

Refer to the Main Collector drawing page 17.

The collectors listed Catalog #904101 and 904110 are compatible with and will operate only on conductor bars listed as Catalog #904025 and 904026 furnished from **COLUMBUS MCKINNON CORPORATION**. The builder must check to ensure that the suggested spacing and location of the conductors will clear all obstructions in the building.



EQUAL SPACING BETWEEN SUPPORTS  
NOT TO EXCEED 5'-0"

CATALOG 904025

CATALOG 904026

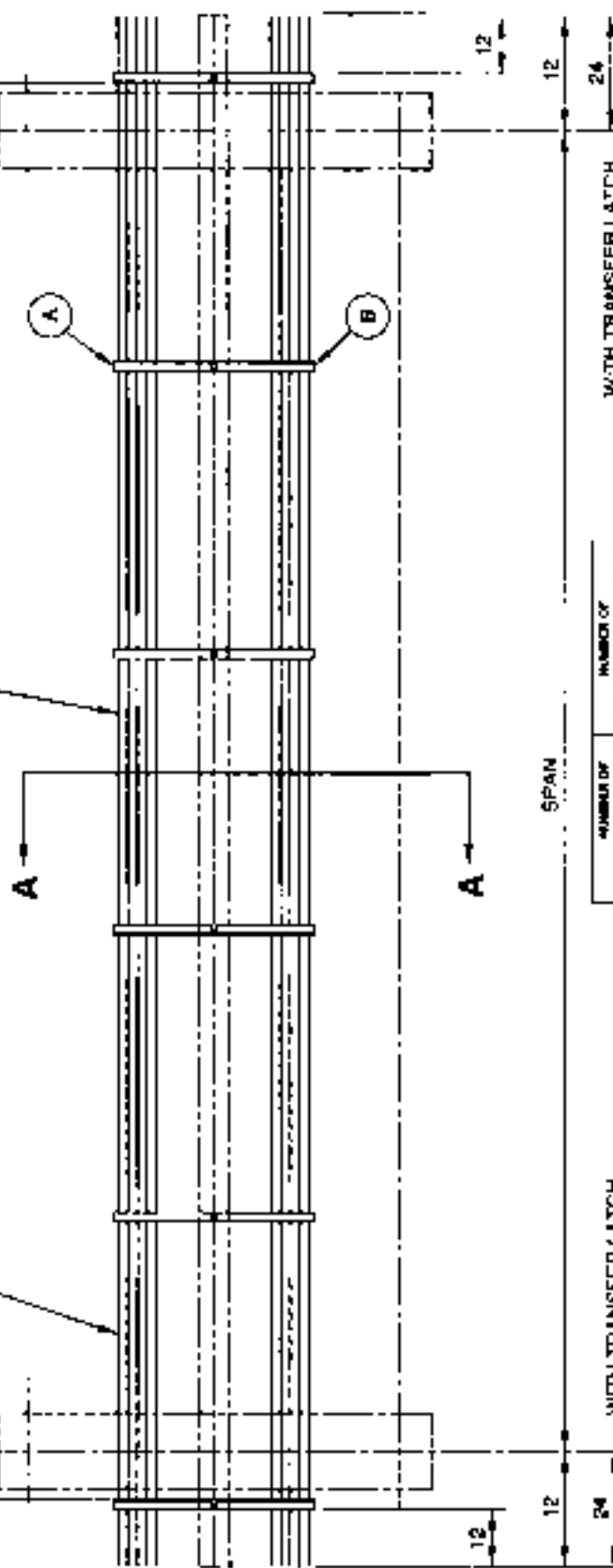

WITH TRANSFER LATCH

WITH TRANSFER LATCH

NUMBER OF SUPPORTED POINTS PER TOWER / CROSSING POST	NUMBER OF COLLECTOR CONDUCTORS PER TOWER / CROSSING POST	NUMBER OF CONDUCTORS PER TOWER / CROSSING POST
1	1	1
2	2	2
3	3	3
4	4	4
5	5	5
6	6	6
7	7	7
8	8	8
9	9	9
10	10	10
11	11	11
12	12	12
13	13	13
14	14	14
15	15	15
16	16	16
17	17	17
18	18	18
19	19	19
20	20	20

TYPE OF SUPPORT	NUMBER OF CONDUCTORS
1	1
2	2
3	3
4	4
5	5
6	6
7	7
8	8
9	9
10	10
11	11
12	12
13	13
14	14
15	15
16	16
17	17
18	18
19	19
20	20

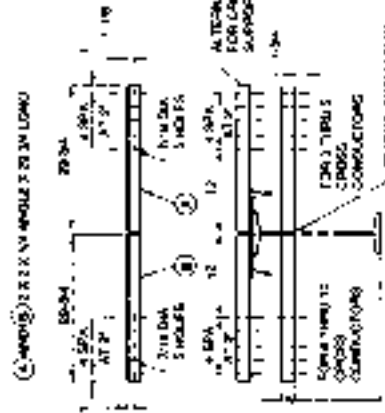

ALTERNATE POSITION  
FOR CROSS CONDUCTOR  
SUPPORTS

SECTION A-A

CONDUCTOR KIT CAT. NO. 904025  
FOR USE WITH ONE CONDUCTOR KIT  
KIT DESCRIPTION  
1. 10 INSULATED 1/2" DIA. 1/4" THICK  
2. INSULATED 1/2" DIA. 1/4" THICK  
3. INSULATED 1/2" DIA. 1/4" THICK  
4. INSULATED 1/2" DIA. 1/4" THICK  
5. INSULATED 1/2" DIA. 1/4" THICK  
6. INSULATED 1/2" DIA. 1/4" THICK  
7. INSULATED 1/2" DIA. 1/4" THICK  
8. INSULATED 1/2" DIA. 1/4" THICK  
9. INSULATED 1/2" DIA. 1/4" THICK  
10. INSULATED 1/2" DIA. 1/4" THICK  
11. INSULATED 1/2" DIA. 1/4" THICK  
12. INSULATED 1/2" DIA. 1/4" THICK  
13. INSULATED 1/2" DIA. 1/4" THICK  
14. INSULATED 1/2" DIA. 1/4" THICK  
15. INSULATED 1/2" DIA. 1/4" THICK  
16. INSULATED 1/2" DIA. 1/4" THICK  
17. INSULATED 1/2" DIA. 1/4" THICK  
18. INSULATED 1/2" DIA. 1/4" THICK  
19. INSULATED 1/2" DIA. 1/4" THICK  
20. INSULATED 1/2" DIA. 1/4" THICK



CONDUCTOR KITS FOR INSULATED FIGURE 18" BAR

CROSS CONDUCTOR ARRANGEMENT

MAIN COLLECTOR SELECTION CHART	
USE 30 AMP COLLECTOR WITH HOISTS MOTORS THRU 10 HORSEPOWER	CATALOG 904101
USE 100 AMP COLLECTOR WITH HOISTS MOTORS OVER 10 HORSEPOWER	904110

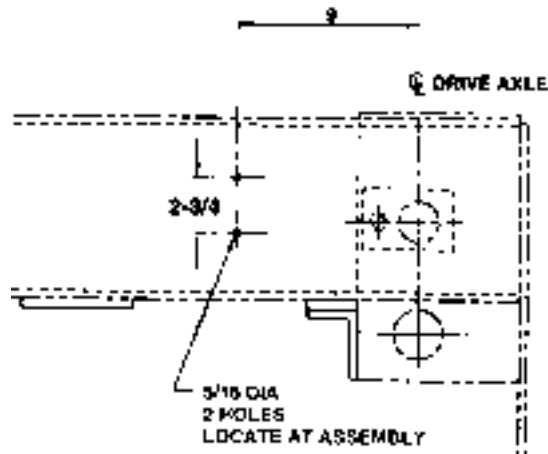
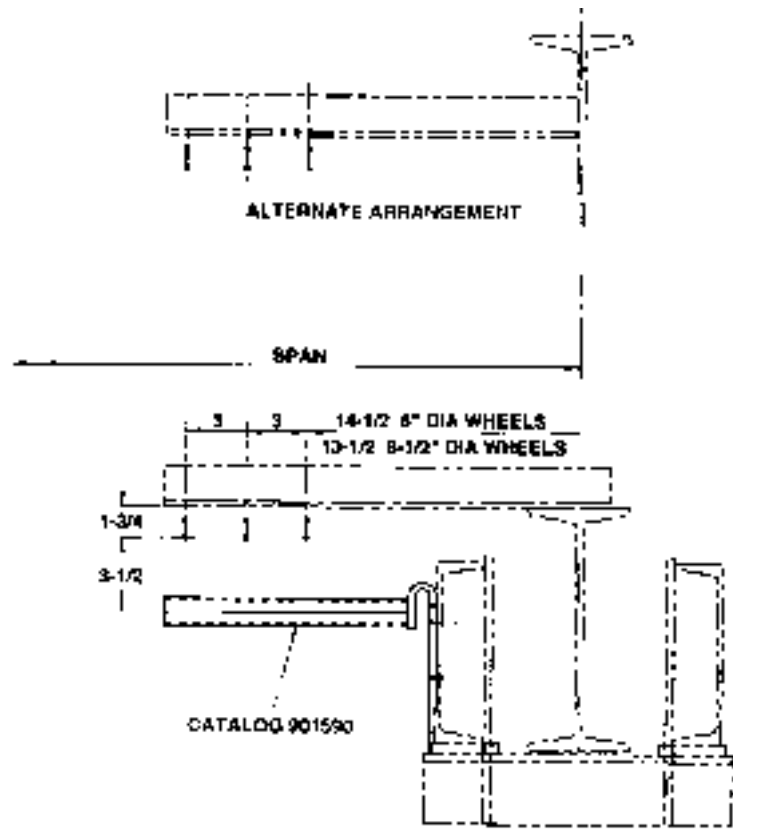

439856

## INSTALLATION OF CRANE BRIDGE

### WARNING

Be certain that electrical power supply to runway current conductors (if used) is "off" and locked in the open position.

**NOTE:** Minimum runway beam size allows vertical clearance for bridge wheels between runway beam flanges. Encroachment of flange connections into this area may cause interference.

1. **Open End Runway.** If one end of the crane runway is open and no interference is encountered the crane bridge can be placed on the end of the runway. First check distance between wheels. The distance between the inside faces of the wheel flanges should be the width of the bottom flange of the runway beam plus 1/4". See Figure E. Note also that the dimensions from the back of the wheels to the side of the truck should be equal as shown in Figure E. If wheel adjustment is required, see paragraph 4. If wheels do not require adjusting, lift crane bridge so that wheels are level with contact surface on runway beam. Carefully move crane bridge onto runway.

### WARNING

If crane bridge is mounted on an open-end runway rail, then end stops must be installed to prevent crane bridge from running off the end of the runway rail resulting in injury to the operator and others and damages to the load and other property. End stops per trolley stop table on Bridge Assembly Drawing, may be used and installed per instructions given.

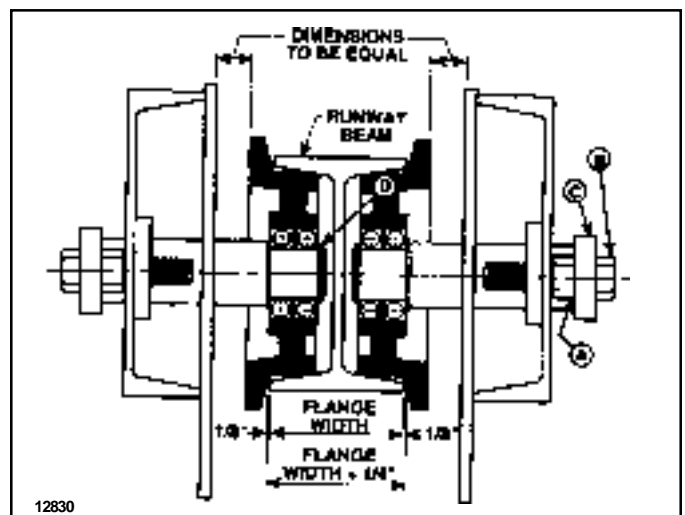

12830

Figure E

2. **Removable Runway Section.** In some installations a removable section of runway may be available. If so, remove runway section, check crane bridge wheel adjustment and install crane bridge as in paragraph 1, and reinstall runway section.

3. **Wheel Removal.** If the methods previously described are not possible, the crane bridge wheels must be removed. Refer to Figure E, page 17. Loosen nut (A) and bolt (B). Back axle and wheel out to truck side by backing out bolt (B). Locking nut (A) may be used to jack out wheel and axle. With external retaining ring pliers with right angle points, remove retaining ring (D). Hold wheel to keep from falling, remove bolt (B) and remove axle. Lift crane bridge to runway level and secure. Reinstall wheels in reverse order of removal. See paragraph 4 for wheel adjustment.

4. **Wheel Adjustment.** Measure the width of the bottom flange of the runway beam and add 1/4". This is to be the dimension between the inside faces of the wheel flanges as shown in Figure E. Lift or jack up truck from the runway beam (to remove weight from the wheels) and adequately secure. Loosen locking nut (A) and adjust bolt (B) on a set of wheels to get the correct dimension between wheel flanges and to maintain equal dimensions from the back of the wheel to the side of the truck as shown in Figure E. After wheels are correctly adjusted tighten lock nut (A) against axle plate (C) making certain that bolt (B) is also tight to axle plate (C). After all wheels are adjusted, lower truck to runway and check clearance between wheel flange and edge of beam (1/8").

5. On a hand geared or a motor driven crane, loosen the two set screws holding each pinion in the geared truck. If LOCTITE has been used, some heat may be necessary to loosen set screws. Align the teeth of the pinions with the geared wheels and tighten the set screws.

### NOTICE

It is recommended that for positive locking of the drive pinions (Figure 1, Ref. No. 18) on hand geared and motor driven end trucks, the following procedure be used (after wheel adjustment is complete).

- A. Make sure the area on the shaft under the drive pinions in their adjusted position is free from oil and dry. Use a suitable non-oily solvent or LOCTITE Safety Solvent 755.
- B. Align the teeth of the pinions with the geared wheels and lightly tighten the set screws which engage the pinion keys.
- C. Remove the other set screws and rotate the pinion shaft until these set screw holes are above horizontal.
- D. Apply LOCTITE 290 in the set screw holes until it can be seen flowing from the pinion bore at the shaft.

- E. Replace set screws and tighten fully. For maximum locking, use a **new**, high quality 1/8" hex key and apply pressure at the end of the longer arm until it bends about 30 °.
- F. Loosen set screws over keys, apply a few drops of LOCTITE 290 and retighten as in Step E above.



### WARNING

The end trucks of this crane were equipped with safety lugs held by high strength bolts when shipped. Be certain that these safety lugs are firmly bolted in place prior to crane use.

**NOTE:** It is suggested that hoist and trolley be installed on crane bridge at this time so all wiring and connections can be completed.



### WARNING

This equipment must be effectively grounded according to the National Electrical Code, or other applicable codes. If the grounding method used is through the truck wheels, then each section of runway must be grounded by metal-to-metal connection to the building ground. Certain environments may prevent proper grounding by this means and in this case a separate grounding conductor should be provided.

### FUSE AND MAINLINE DISCONNECT PANELS

Mainline disconnect panels and fuse bridge control panels are provided as options to assist users in complying with OSHA codes. When ordering with crane, they will be completely installed inside of electrical enclosures.

Electrical service is to be connected to crane equipped with fuse panels and mainline disconnect panels as shown in wiring diagram. Wiring diagrams are in Part No. 113533-74.



### CAUTION

Power supply must be same voltage, frequency and phase as specified on crane motor nameplate

### LUBRICATION

- a. Wheel bearings are permanently lubricated and require no additional lubricant.

b. Drive wheel gears are to be lubricated with an open type gear grease which is heavy, plastic, extreme pressure and tacky; such as MOBILTAC 275 NC or equal.

c. The hollow shaft worm gear reducer lubricant should be changed every year or 2000 hours of service for moderate usage. The lubricant should be changed more frequently if the service is more severe. Use one pint of AGMA lubricant number 7, compounded, if the ambient temperature is 15° to 60°F or AGMA lubricant number 8, compounded, if the ambient temperature is 50° to 125°F.

d. It is recommended that the areas of the cross shaft covered by gear reducers, bearings and couplings be coated with FEL-PRO C5-A, or equal, anti-seize lubricant.

Before crane operation the vent plug must be in the proper location in the gear reducer. The vent plug replaces the pipe plug in the highest location on the end of the gear reducer (see Figure 5).

## OPERATION

Prior to placing the crane into service, OSHA requires that the user perform and record certain tests including proof loading of the crane. Refer to ANSI B30.11 for information concerning these requirements.

Each operator should be thoroughly instructed in the operation of the crane, its' limitations both in capacity and bridge and hoist travel, as well the cranes' safety features.

## INSPECTION

The crane should be inspected at the beginning of each shift. All functional mechanisms should be in good working order. Check limit switches, brakes, electrical equipment, and other SAFETY devices. Check crane operation without load. Any unusual sounds, vibrations, anything wrong or apparently wrong should be reported to the operators' supervisor immediately. Inspect hoist and trolley as recommended in manufacturer's hoist and trolley manual.

 <b>WARNING</b>
<b>Do not operate a crane, hoist or trolley having unusual vibrations, sounds, warnings or with anything wrong or apparently wrong. Danger may be present that the crane operator cannot see. Determine and correct cause of unusual conditions and make certain the crane can be operated SAFELY.</b>

Complete inspection of the crane is to be performed at least every six months and more frequently when conditions require.

## OPERATING PRECAUTIONS

 <b>WARNING</b>
<b>These crane bridges are not designed nor intended to be used for support or transport of people or for transporting loads over people.</b>

Safe operation of an overhead hoist is the operator's responsibility. Listed below are some basic rules that can make an operator aware of dangerous practices to avoid and precautions to take for his own safety and the safety of others. Observance of these rules in addition to frequent examinations and periodic inspection of the equipment may save injury to personnel and damage to equipment.

**DO NOT** load bridge beyond rated capacity.  
**DO NOT** subject bridge to side loads. Always center trolley over load when hoisting.

**DO NOT** stand and **DO NOT** cause or allow others to stand or get under any load the bridge is supporting. **DO** keep clear, and make sure others keep clear, of any load the bridge is supporting.

**DO NOT** attempt to operate crane bridge before completing tests and adjustments.

**DO NOT** ram bridge into end stops, other bridge, or any obstruction on beam. Improper and careless operation can result in a hazardous condition for operator and load.

**ALWAYS** be sure load is clear of obstruction before traversing load.

If crane bridge is mounted on an open-end runway rail, then end stops must be installed to prevent crane bridge from running off the end of the runway rail resulting in injury to the operator and others and damages to load and other property. End stops per trolley stop table in Bridge Assembly Drawing may be used and installed per instructions given.

Refer to hoist and trolley instruction manuals for safety warnings on hoist and trolleys.

Read and comply with ANSI B30.11 Monorails and Underhung Cranes, latest edition.

Read and comply with all local, state and national safety codes.

## MAINTENANCE

Inspect the bridge on a regular maintenance schedule. Check to make sure wheel axle adjustment bolts and all connections are tight. Check wheel tread surfaces for wear or damage. Check truck sides for any evidence of overload or damage. Replace any worn or damaged parts using only factory approved replacement parts.

## REPLACEMENT PARTS

The following parts list and illustrations cover standard model **COLUMBUS MCKINNON CORPORATION** cranes. Typical units are used as the basis for the exploded parts illustrations; therefore, certain variations may occur from the parts information given. For this reason always give the catalog number, model number, motor horsepower, voltage, phase and frequency when ordering replacement parts. For motors, gearboxes, and electrical components, give complete nameplate data.

The factory recommends complete replacement of the motor or gearbox. Gearbox service is available, however, from your local authorized **COLUMBUS MCKINNON CORPORATION** repair station.

**The numbers assigned to the parts of our various assemblies in our parts list are not the part numbers used in manufacturing the part. They are identification numbers, that when given with the catalog number, permits us to identify, select or manufacture, and ship the correct part needed.**

### INDEX OF PARTS ILLUSTRATIONS

Title	Figure No.	Page No.
Geared Truck (Catalog Numbers – See Figure 1) .....	1	20
Cross Shaft Support (Catalog Number 904625) .....	2	22
Coupling (Catalog Number 8280) .....	3	22
Hand Chain Drive (Catalog Numbers 8282 and 913115) .....	4	23
Gear Reducer and Motor (Catalog Numbers – See Figure 5) .....	5	24
Electrical Enclosure (Catalog Numbers – See Figure 6) .....	6	26

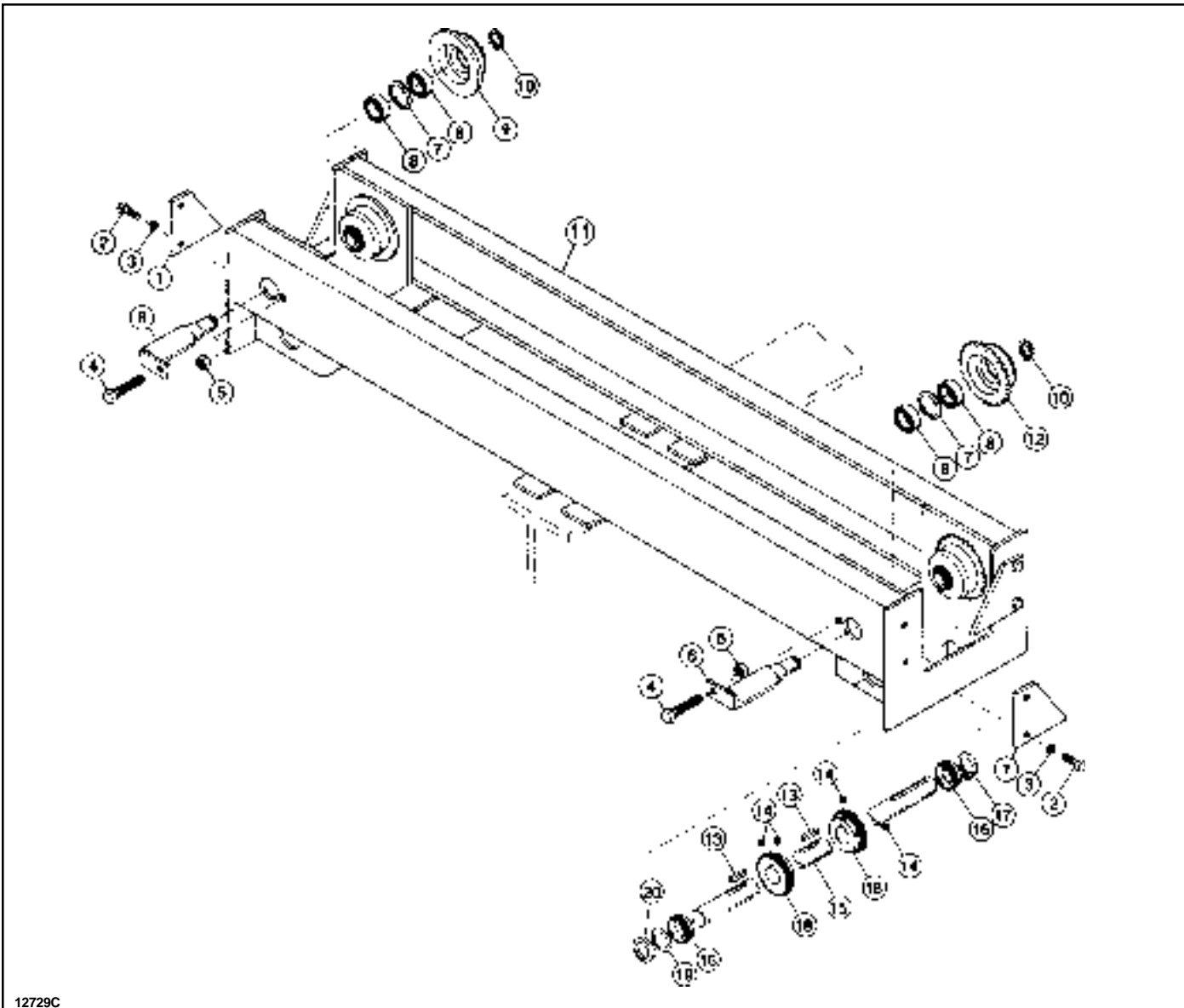

12729C

Figure 1. Geared Truck. (Catalog Numbers 913101, 913101W1, 913101W2, 913102, 913102W1, 913102W2, 913106, 913106W1, 913106W2, 913107, 913107W1 and 913107W2).

Figure 1. Geared Truck. (Catalog Numbers 913101, 913101W1, 913101W2, 913102, 913102W1, 913102W2, 913106, 913106W1, 913106W2, 913107, 913107W1 and 913107W2) (Continued).

Ref. No.	Part Number		Description	Qty. Req'd
	6-1/2" Wheels	8" Wheels		
1	STK-101	STK-102	Drop Lugs	4
2			High Strength Hex Head Bolt – SAE Grade 5	8
	STK-103	--	3/4-10 x 1-3/4	
	--	STK-104	1-8 x 2	
3	STK-105	--	Spring Lockwasher (3/4)	8
	--	STK-106	Spring Lockwasher (1)	8
4			Hex Head Tap Bolt – SAE Grade 5	4
	STK-107	--	3/4-10 x 4-1/4	
	--	STK-108	1-8 x 4-1/4	
5	STK-109	--	Heavy Hex Jam Nut (3/4-10)	4
	--	STK-110	Heavy Hex Jam Nut (1-8)	4
6	STK-111	STK-112	Wheel Axle Weldment	4
7	STK-113	STK-114	Retaining Ring	4
8	STK-115	STK-116	Ball Bearing	8
9	STK-117	STK-118	Plain Wheel	2
10	STK-119	STK-120	Retaining Ring	4
11			Truck Weldment	1
			6'-6" Wheelbase	
	STK-121	--	For 4-5/8" thru 6" Runway Beam Flange Width	
	STK-122	--	For 6-1/8" thru 8-1/2" Runway Beam Flange Width	
	STK-123	--	For 8-5/8" thru 11" Runway Beam Flange Width	
	--	STK-124	For 5" thru 7" Runway Beam Flange Width	
	--	STK-125	For 7-1/8" thru 9-1/2" Runway Beam Flange Width	
	--	STK-126	For 9-5/8" thru 12" Runway Beam Flange Width	
			8'-0" Wheel base	
	STK-127	--	For 4-5/8" thru 6" Runway Beam Flange Width	
	STK-128	--	For 6-1/8" thru 8-1/2" Runway Beam Flange Width	
	STK-129	--	For 8-5/8" thru 11" Runway Beam Flange Width	
	--	STK-130	For 5" thru 7" Runway Beam Flange Width	
	--	STK-131	For 7-1/8" thru 9-1/2" Runway Beam Flange Width	
	--	STK-132	For 9-5/8" thru 12" Runway Beam Flange Width	
12	STK-133	STK-134	Geared Wheel	2
13	STK-135	STK-135	Square Keys	2
14	STK-136	STK-136	Hex Socket Head Set Screws	4
15			Pinion Shaft	1
	STK-137	--	For 4-5/8" thru 6" Runway Beam Flange Width	
	STK-138	--	For 6-1/8" thru 8-1/2" Runway Beam Flange Width	
	STK-139	--	For 8-5/8" thru 11" Runway Beam Flange Width	
	--	STK-140	For 5" thru 7" Runway Beam Flange Width	
	--	STK-141	For 7-1/8" thru 9-1/2" Runway Beam Flange Width	
	--	STK-142	For 9-5/8" thru 12" Runway Beam Flange Width	
16	STK-143	STK-143	Ball Bearing with Snap Ring	2
17	STK-144	STK-144	Retaining Ring	1
18	STK-145	STK-145	Pinion	2
19	STK-146	STK-146	Machinery Bushing	1
20	STK-147	STK-147	Clamp Collar	1

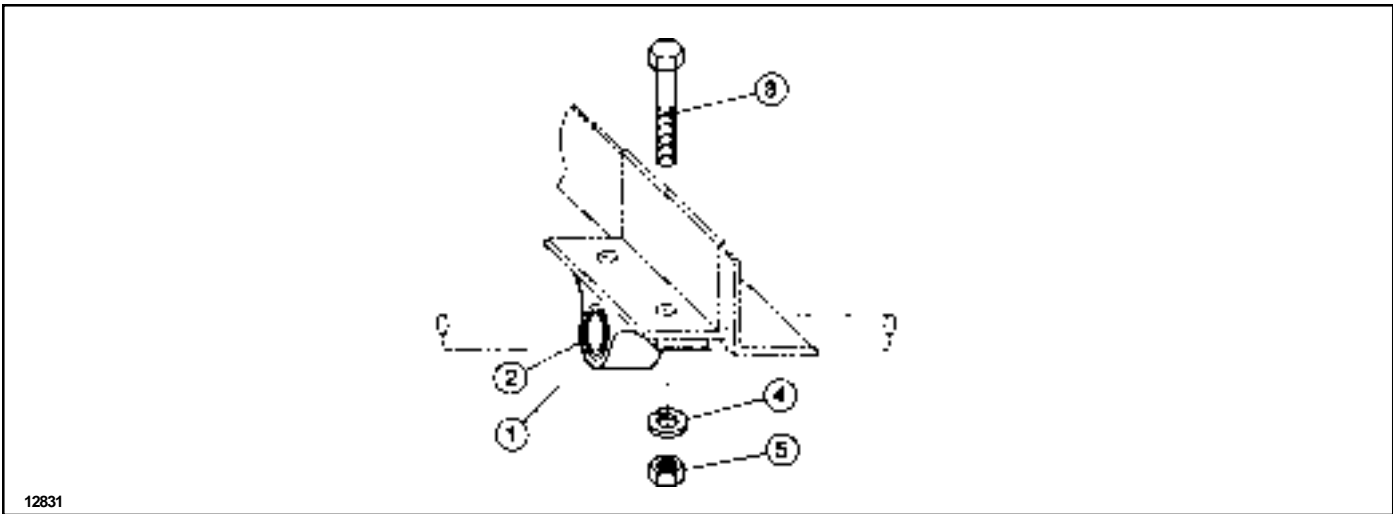

Figure 2. Cross Shaft Bearing Assembly. (Catalog Number 904625).

Ref. No.	Part Number	Description	Qty. Req'd
1	STK-201	Pillow Block	1
2	--	Locking Collar (Included with Pillow Block)	1
3	STK-202	Hex Head Bolt (1/2-13 x 1-1/4)	2
4	STK-203	Spring Lockwasher (1/2)	2
5	STK-204	Hex Nut (1/2)	2

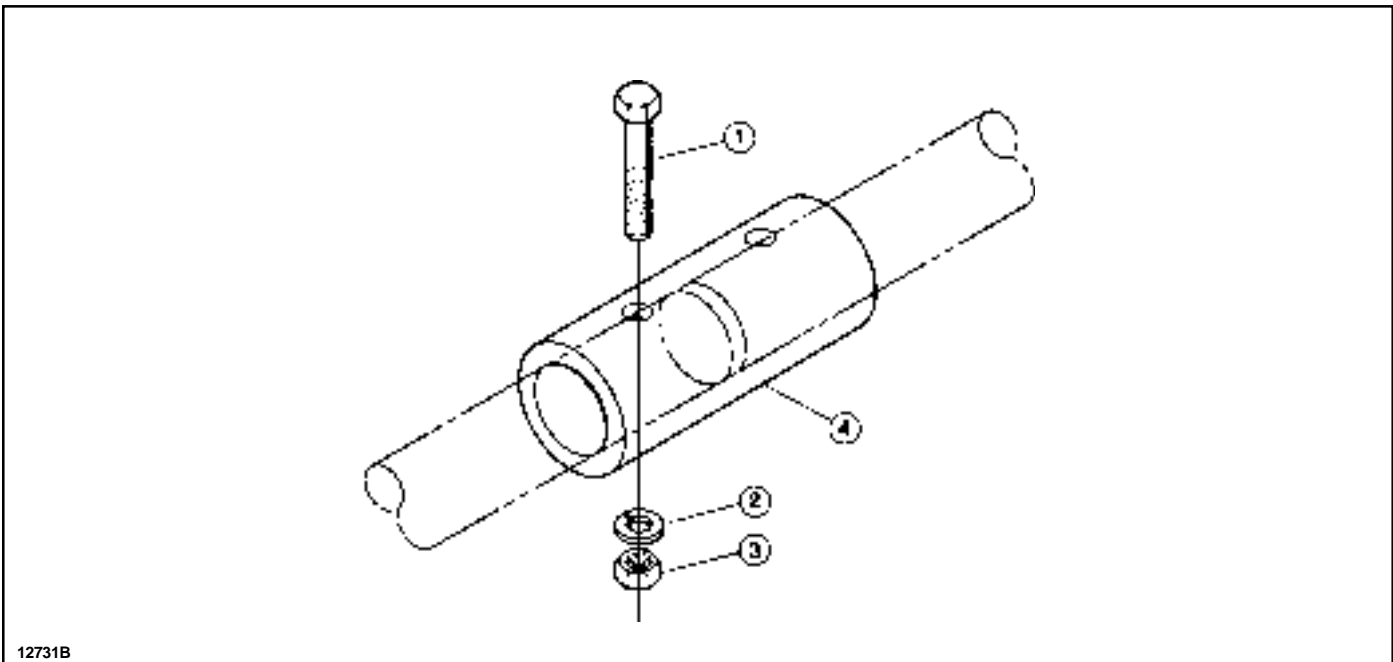

Figure 3. Coupling. (Catalog Number 8280).

Ref. No.	Part Number	Description	Qty. Req'd
1	STK-301	Hex Head Fit Bolt	2
2	STK-302	Spring Lockwasher (3/8)	2
3	STK-303	Heavy Semi-Finish Hex Nut	2
4	STK-304	Coupling	1

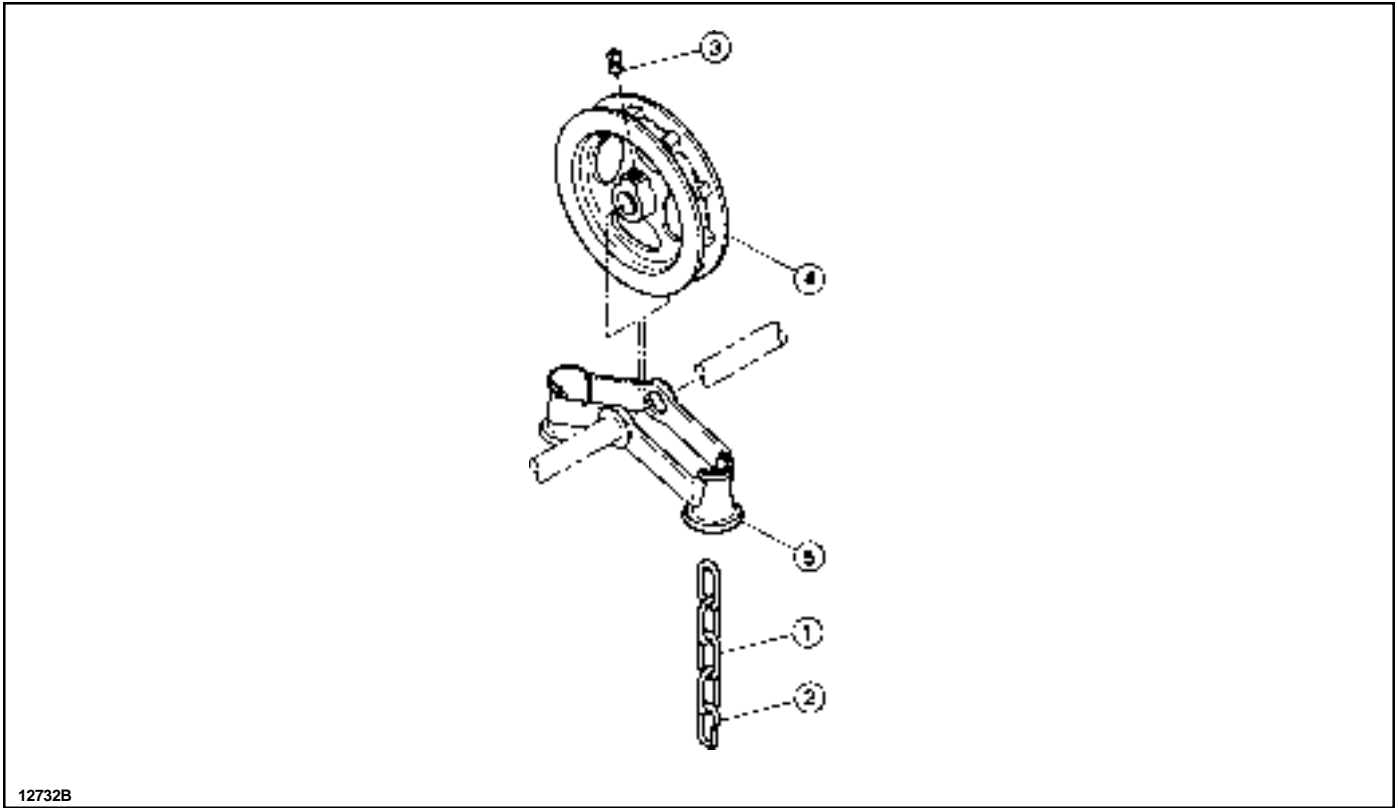

Figure 4. Hand Chain Drive. (Catalog Numbers 8282 and 913115).

Ref. No.	Part Number	Description	Qty. Req'd
1	STK-1104	Catalog Number 8282 Consists of Ref. Nos. 1 and 2: Hand Chain	36 ft.
2	STK-1105		1
3	STK-1101	Catalog Number 913115 Consists of Ref. Nos. 3 thru 5: Square Head Set Screw, Cup Point (3/8-16 x 1 Pltd.)	1
4	STK-401		1
5	STK-402		1

**NOTES**

---

---

---

---

---

---

---

---

---

---

---

---

---

---

---

---



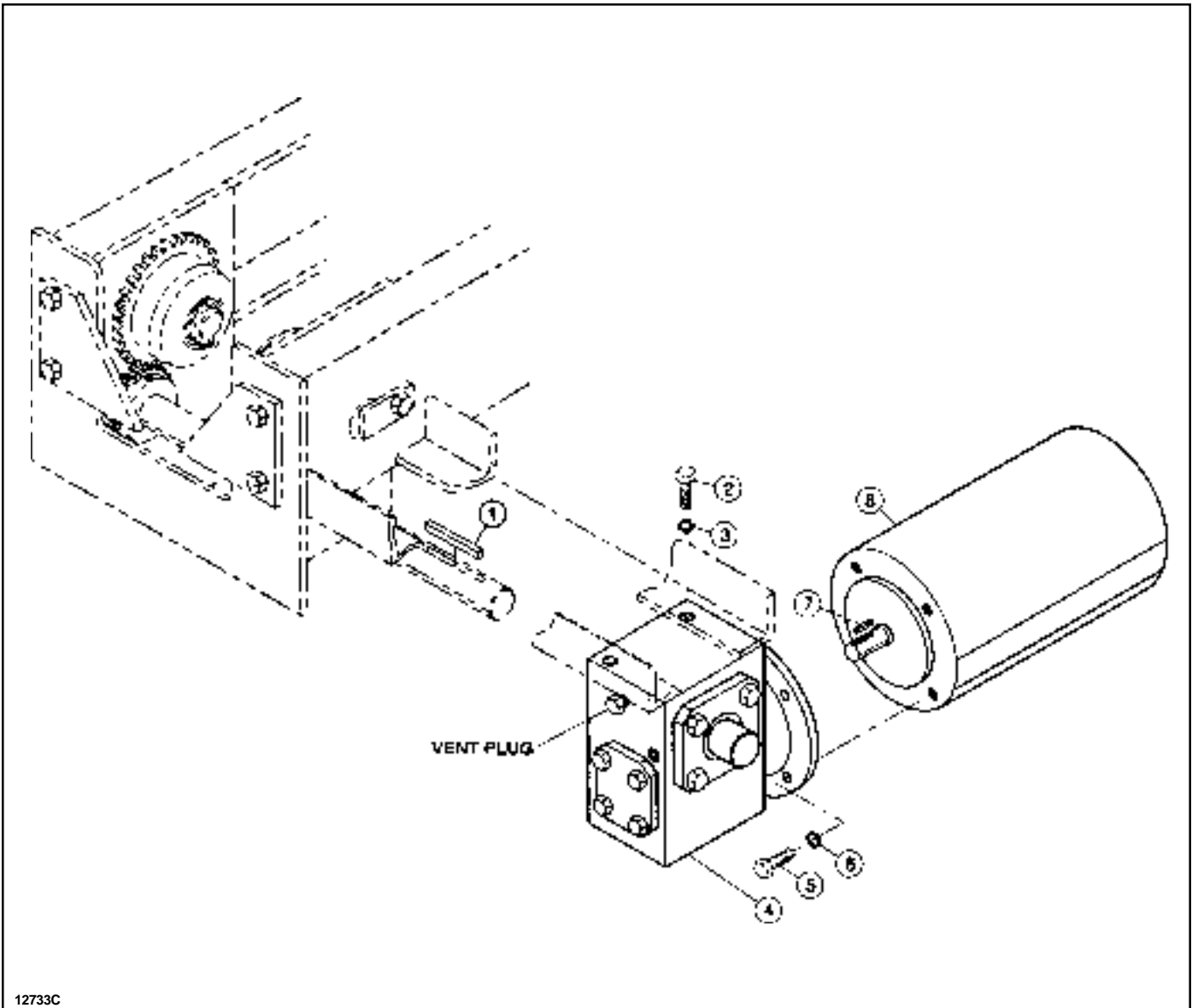

Figure 5. Gear Reducer. (Catalog Numbers 913108 thru 913112) and Motor (Catalog Numbers 905148 thru 905150, 905381, 905382, 905394 thru 905396, 913120, 913121, 913124, 913125, 913128 thru 913134, 913139 thru 913141 and 913145 thru 913147).

Ref. No.	Key Number	Description	Qty. Req'd
1	STK-501	Catalog Numbers 913108 thru 913112 Consist of Ref. Nos. 1 thru 6: Key	1
2	STK-502	Self-Locking Socket Head Cap Screw (5/16-18 x 7/8)	4
3	STK-503	Spring Lockwasher (5/16)	4
4		Gear Reducer	1
	STK-504	5:1 Gear Ratio (Cat. No. 913108)	
	STK-505	7.5:1 Gear Ratio (Cat. No. 913109)	
	STK-506	10:1 Gear Ratio (Cat. No. 913110)	
	STK-507	15:1 Gear Ratio (Cat. No. 913111)	
	STK-508	20:1 Gear Ratio (Cat. No. 913112)	
5	STK-509	Hex Head Bolt (3/8-16 x 1)	4
6	STK-510	Spring Lockwasher (3/8)	4
		Catalog Numbers 913120, 913121, 913124, 913125, 913128, 913129, 913132 thru 913134, 913139 thru 913141 and 913145 thru 913147	
7	STK-511	Consist of Ref. Nos. 7 and 8: Key	1

Figure 5. Gear Reducer. (Catalog Numbers 913108 thru 913112) and Motor (Catalog Numbers 905148 thru 905150, 905381, 905382, 905394 thru 905396, 913120, 913121, 913124, 913125, 913128 thru 913134, 913139 thru 913141 and 913145 thru 913147) (Continued).

Ref. No.	Key Number	Description	Qty. Req'd
8		Motor:	1
		Single Speed:	
		208-230/460-3-60:	
	STK-527	1/2 HP, 1800 RPM (Cat. No. 905381)	
	STK-512	3/4 HP, 1800 RPM (Cat. No. 913120)	
	STK-513	1 HP, 1800 RPM (Cat. No. 913124)	
	STK-514	1-1/2 HP, 1800 RPM (Cat. No. 913128)	
	STK-528	2 HP, 1800 RPM (Cat. No. 913130)	
		575-3-60:	
	STK-529	1/2 HP, 1800 RPM (Cat. No. 905382)	
	STK-515	3/4 HP, 1800 RPM (Cat. No. 913121)	
	STK-516	1 HP, 1800 RPM (Cat. No. 913125)	
	STK-517	1-1/2 HP, 1800 RPM (Cat. No. 913129)	
	STK-530	2 HP, 1800 RPM (Cat. No. 913131)	
		Two Speed:	
		208-230-3-60:	
	STK-531	.5 / .17 HP, 1800 RPM (Cat. No. 905394)	
	STK-518	.75 / .25 HP, 1800 RPM (Cat. No. 913132)	
	STK-519	1 / .33 HP, 1800 RPM (Cat. No. 913139)	
	STK-520	1.5 / .5 HP, 1800 RPM (Cat. No. 913145)	
	STK-532	2 / .67 HP, 1800 RPM (Cat. No. 905148)	
		460-3-60:	
	STK-533	.5 / .17 HP, 1800 RPM (Cat. No. 905395)	
	STK-521	.75 / .25 HP, 1800 RPM (Cat. No. 913133)	
	STK-522	1 / .33 HP, 1800 RPM (Cat. No. 913140)	
	STK-523	1.5 / .5 HP, 1800 RPM (Cat. No. 913146)	
	STK-534	2 / .67 HP, 1800 RPM (Cat. No. 905149)	
		575-3-60:	
	STK-535	.5 / .17 HP, 1800 RPM (Cat. No. 905396)	
	STK-524	.75 / .25 HP, 1800 RPM (Cat. No. 913134)	
	STK-525	1 / .33 HP, 1800 RPM (Cat. No. 913141)	
	STK-526	1.5 / .5 HP, 1800 RPM (Cat. No. 913147)	
	STK-536	2 / .67 HP, 1800 RPM (Cat. No. 905150)	

**NOTES**

---



---



---



---



---



---



---



---



---



---



---



---



---



---



---

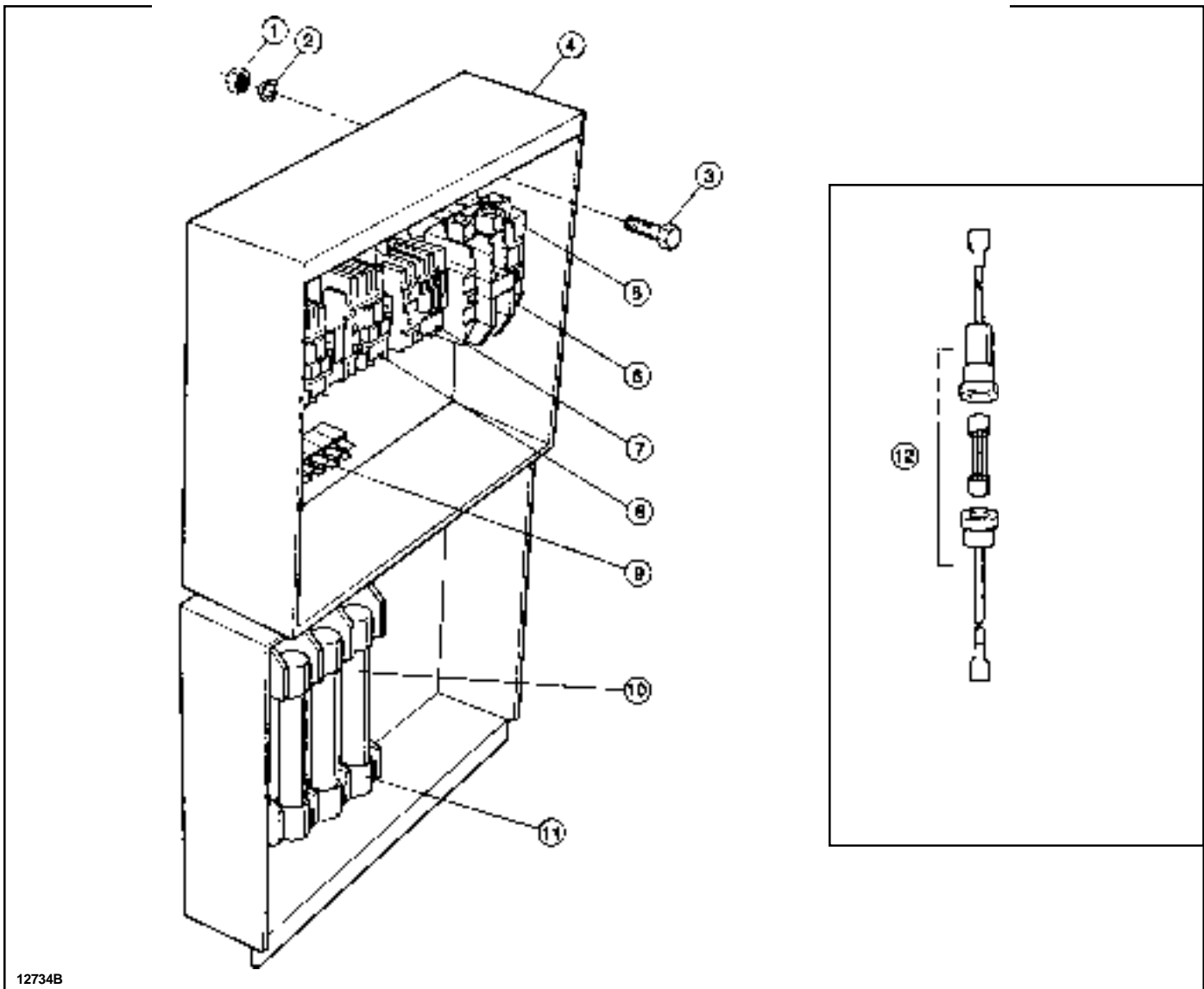

12734B

Figure 6. Electrical Enclosure. (Catalog Numbers 905385, 905386, 905387, 905397, 905398, 905399, 913155 thru 913158 and 913165 thru 913169).

Ref. No.	Key Number	Description	Qty. Req'd
1	STK-1306	Hex Nut (1/4-20)	2
2	STK-1307	Spring Lockwasher (1/4)	2
3	STK-601	Hex Head Bolt (1/4-20 x 2-1/2)	2
4	STK-1309	Electrical Enclosure	1
5		Transformer	1
	STK-602	208/115V or 230/115V	
	STK-1313	460/115V	
	STK-1314	575/115V	
6	STK-1317	Mainline Contactor	1
7	STK-1319	Accelerating Contactor (For 2 Speed Cranes Only)	1
8	STK-1320	Reversing Contactor	1
9	STK-603	Terminal Board	1
10		Fuses	3
	STK-604	6A, 250V	
	STK-605	10A, 250V	
	STK-606	15A, 250V	
	STK-1324	3A, 600V	
	STK-607	6A, 600V	



## Recommended Spare Parts for Your Chain Hoist

Certain parts of your crane will, in time, require replacement under normal wear conditions. It is suggested that the following parts be purchased for your crane as spares for future use.

- 1 Set of Wheels
- 1 Set of Wheel Bearings
- 1 Set of Fuses
- 1 Set of Contactors

**NOTE:** When ordering parts always furnish Catalog Number and Part Number.

Parts for your crane are available from your authorized repair station. For the location of your nearest repair station, write:



P.O. BOX 1000  
Forrest City, Arkansas 72335  
800 999-6318 Phone  
800 766-0223 Fax

414 West Broadway Avenue  
P.O. Box 769  
Muskegon, Michigan 49443-0769  
(800) 742-9269 Phone  
(800) 742-9270 Fax

53-D Cowansview Road  
Cambridge, Ontario N1R 7L2  
(519) 621-3201 Phone  
(519) 621-3125 Fax

# WARRANTY

## **WARRANTY AND LIMITATION OF REMEDY AND LIABILITY**

A. Seller warrants that its products and parts, when shipped, and its work (including installation, construction and start-up), when performed, will meet applicable specifications, will be of good quality and will be free from defects in material and workmanship. All claims for defective products or parts under this warranty must be made in writing immediately upon discovery and, in any event, within one (1) year from shipment of the applicable item unless Seller specifically assumes installation, construction or start-up responsibility. All claims for defective products or parts when Seller specifically assumes installation, construction or start-up responsibility, and all claims for defective work must be made in writing immediately upon discovery and, in any event, within one (1) year from completion of the applicable work by Seller, provided, however, all claims for defective products and parts made in writing no later than eighteen (18) months after shipment. Defective items must be held for Seller's inspection and returned to the original f.o.b. point upon request. **THE FOREGOING IS EXPRESSLY IN LIEU OF ALL OTHER WARRANTIES WHATSOEVER, EXPRESS, IMPLIED AND STATUTORY, INCLUDING, WITHOUT LIMITATION, THE IMPLIED WARRANTIES OF MERCHANTABILITY AND FITNESS.**

B. Upon Buyer's submission of a claim as provided above and its substantiation, Seller shall at its option either (i) repair or replace its product, part or work at either the original f.o.b. point of delivery or at Seller's authorized service station nearest Buyer or (ii) refund an equitable portion of the purchase price.

C. This warranty is contingent upon Buyer's proper maintenance and care of Seller's products, and does not extend to normal wear and tear. Seller reserves the right to void warranty in event of Buyer's use of inappropriate materials in the course of repair or maintenance, or if Seller's products have been dismantled prior to submission to Seller for warranty inspection.

D. The foregoing is Seller's only obligation and Buyer's exclusive remedy for breach of warranty, and is Buyer's exclusive remedy hereunder by way of breach of contract, tort, strict liability or otherwise. In no event shall Buyer be entitled to or Seller liable for incidental or consequential damages. Any action for breach of this agreement must be commenced within one (1) year after the cause of action has occurred.