



TOLL FREE 1-800-392-0146

www.hoist-parts.com
parts@sisscohoist.com

SISSCO ONLINE HOIST PARTS DISTRIBUTION CENTER MANUALS



A Reputation for Service Since 1972
Certified WBE



ASSEMBLY INSTRUCTION MANUAL

DOUBLE GIRDER TOP RUNNING BRIDGES WITH INDIVIDUAL MOTOR DRIVEN AND HAND GEARED TRUCKS

Rated Loads;

1 thru 25 tons / 2000 thru 50000 lbs.

1 thru 25 tonnes / 1000 thru 25000 kg.

Follow all instructions and warnings in building this bridge

The building of any bridge presents some risk of personal injury or property damage. That risk is greatly increased if proper instructions and warnings are not followed. Before starting construction the builder should become thoroughly familiar with all warnings, instructions and recommendations in this manual.

Retain this manual for future reference and use.



**TO BUILD TOP RUNNING
DOUBLE GIRDER CRANE BRIDGES**

THE INFORMATION CONTAINED IN THIS MANUAL IS FOR INFORMATIONAL PURPOSES ONLY AND THE MANUFACTURER DOES NOT WARRANT OR OTHERWISE GUARANTEE (IMPLIEDLY OR EXPRESSLY) ANYTHING OTHER THAN THE COMPONENTS MANUFACTURED AND ASSUMES NO LEGAL RESPONSIBILITY (INCLUDING, BUT NOT LIMITED TO CONSEQUENTIAL DAMAGES) FOR INFORMATION CONTAINED IN THIS MANUAL.

GENERAL

The assembly and manufacturing instructions in this manual are for use in conjunction with the manufacturers components identified by Catalog numbers listed under the two types of drives covered by this manual on pages 15 and 16.

Although the supplied components are designed to conform with the requirements of CMAA 70, Specification for Top Running Bridge & Gantry Type Multiple Girder Electric Overhead Traveling Cranes and ANSI B30.2, Safety Standard for Overhead and Gantry Cranes, it is the installers responsibility to assure that the finished crane assembly complies in total with all applicable local, state and national codes and standards including those mentioned herein. On a hand powered crane with an electric hoist, a fused safety disconnect switch should be provided and mounted on the bridge near the main collectors. Crane wiring should be done by a licensed electrician and be in accordance with the National Electric Code (ANSI/NFPA 70).

The crane bridges described in this manual are intended for normal indoor service. Bridges to be used for outdoor or unusual service require special consideration.

This manual illustrates specific configurations for the range of coverage shown, specifically from 10 foot thru 60 foot spans and up to and including 25 tonne capacity. Minor deviations to the configurations shown (such as shaft bearing spacing, shaft lengths, etc.) may be made providing that any changes and/or alterations to those shown, be performed only by a properly qualified person. The manufacturer accepts no responsibility for any altered bridge configurations.

Material listed by catalog numbers on pages 15 and 16 are applicable only to crane configurations outlined in this manual, specifically limited to a maximum rated load of 25 tonnes and a maximum span of 60 feet.

Cataloged end trucks listed on page 15 will accommodate rail sizes from 25# thru 85#.

⚠WARNING
NON-FACTORY AUTHORIZATIONS OR MODIFICATION OF EQUIPMENT AND USE OF NON-FACTORY REPAIR PARTS CAN LEAD TO DANGEROUS OPERATION AND INJURY.
TO AVOID INJURY: <ul style="list-style-type: none"> • Do not alter or modify equipment without factory authorization. • Do use only factory provided replacement parts.

RUNWAYS: Runway beams on which these cranes will operate must be amply strong to support crane bridge, hoisting equipment, and rated load. Runway rails must be level and parallel within $\pm 1/8"$. Rail joints must be smooth and held firmly in alignment either by bolted splice bars or welding. Rails should be securely fastened to runway beam.

**MATERIAL TO BE PURCHASED LOCALLY
TO COMPLETE A CRANE BRIDGE**

STRUCTURAL STEEL: All structural steel should be first quality, free from rust and excessive mill scale, and conform to ASTM A 36 Standard Specification for Structural Steel.

For the drawing identifying all dimensions, material sizes, location of cross shafting, brackets, etc.; refer to the following chart:

Bridge Assembly	Page
Individual Drive	9
Hand Powered	10

BRIDGE BEAMS: For each rated load, span and type of bridge select bridge beam size from the tables shown on pages 17 thru 28.

The beam which is selected to be used for the bridge girder must be straight with flanges parallel to each other and flanges 90 degrees to the web. See Figure 1 below.

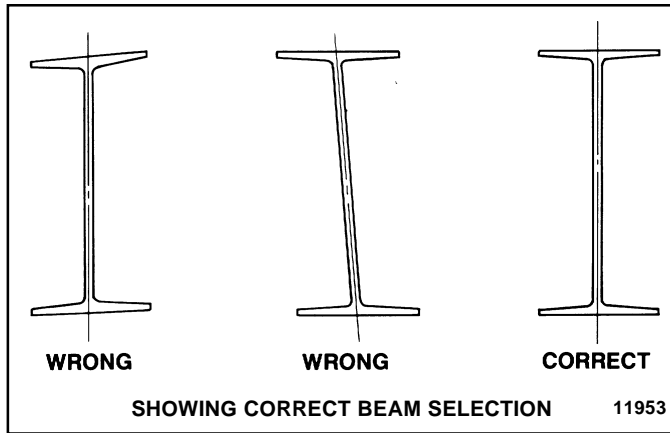

Figure 1.

NOTICE

A. All of the tables used in selection of structural steel beams have been produced by our engineering department using well established design guides for this type of crane bridge. IT IS IMPORTANT THAT ALL INSTRUCTIONS BE FOLLOWED AND THAT RECOMMENDED COMPONENT APPLICATION LIMITS NOT BE EXCEEDED.

B. Assembly of beam and channel requires welding. IT IS EXTREMELY IMPORTANT TO THE SAFETY OF THIS BRIDGE THAT THIS WELDING BE DONE BY A COMPETENT WELL TRAINED WELDER. It is our strong recommendation that the welder used in this construction be qualified as prescribed by the American Welding Society (AWS) Specification for Welding Industrial and Mill Cranes D14.1 - latest issue.

FABRICATION OF GIRDER FOR BRIDGE BEAM WITH CAPPING CHANNEL

Refer to Figure 2. Place channel on supports as shown in Step I. The beam is sighted for camber and placed with camber in direction shown in Step II. Weld one end of the channel to the beam. Clamp, with "C" clamps, the channel to the beam flange. Provide sufficient "C" clamps so as to hold the channel in contact with the beam.

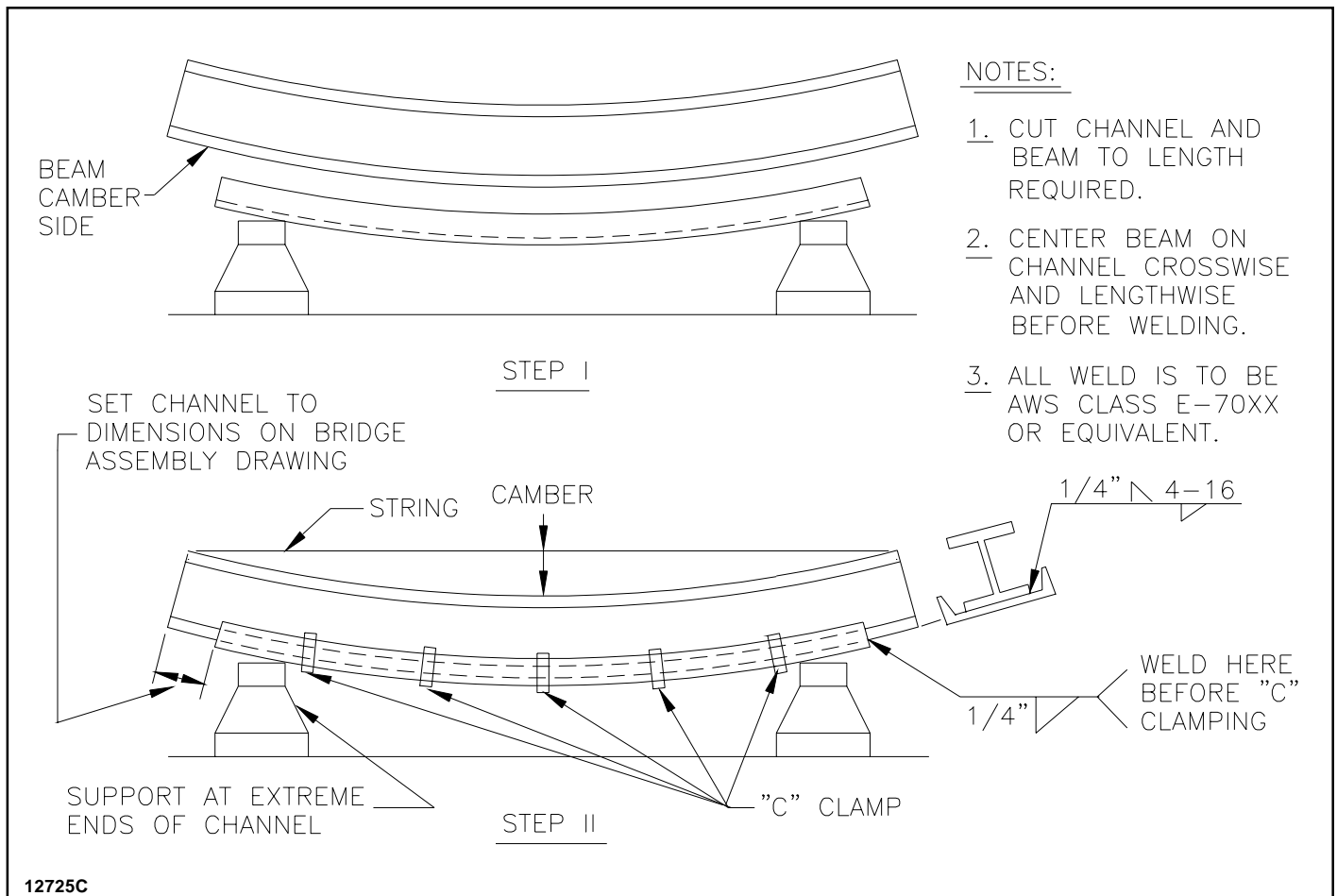



Figure 2.

Weld in accordance with the weld information given, starting at one end, staggering the weld from side to side, proceeding to the opposite end of the channel without interruption. It is important to stagger the weld from side to side in order to retain beam straightness. After welding, draw a taut string from end to end of beam as shown. Beam should either be parallel to string or have some camber. Camber should not exceed 1/888 of span.

 WARNING
<p>Trolley stops (clip angles) must be installed on both ends of the bridge beam to prevent hoist trolley from running off the end of the beam, which could result in injury to the operator and others and damage to the load and other property.</p>

FABRICATION OF GIRDER FOR BRIDGE BEAM WITH VERTICAL PLATE

Refer to Figure 3. Place beam on supports as shown in Step I. The beam is sighted for camber and placed with camber in direction shown in Step II. Place plate vertically against the flanges of the girder and tack weld the plate in place.

Weld in accordance with the weld information given, starting at one end of the girder, staggering the weld on top and bottom of the girder, proceeding to the opposite end of the girder without interruption. After welding, draw a taut string from end to end of beam as shown. Beam should either be parallel to string or have some camber. Camber should not exceed 1/888 of span.

CROSS SHAFTS: For hand geared cranes, cross shafts are required. The cross shafts are to be of AISI 1018 cold drawn steel, with standard mill tolerance of +.000", -.002". For shaft diameter and lengths, refer to Figure 10, Hand Geared Bridge Assembly. The builder must check that the cross shaft couplings clear cross shaft bearings.

ASSEMBLING BRIDGE GIRDER TO END TRUCKS

1. Refer to Figure 4-Bridge "Whale's Tail" Bolted End Connection, Figure 4B-Bolt Plated End Connection and Figure 5-Bridge Welded End Connection. Figure 4 shows a girder end connection that may be optionally purchased as a kit. Figure 4B shows optional bolted plate girder connection that may be purchased. Figure 5 is an end connection that may be fabricated by the crane builder. Make the notch to the dimensions shown with a 1/2" radius at the intersection of the cuts with a cutting torch and smooth the burned area by grinding. Support beam about two feet from each end on a pair of horses, or other suitable support (adjustable, with clamping ability is preferred). Place beam on supports so that camber side is at top. In case of beams with vertical plates the plates are to the outside of the crane (away from the centerline).

When setting up the beams on supports, make certain that **the top flanges at the trucks are level** as shown in Figure 6.

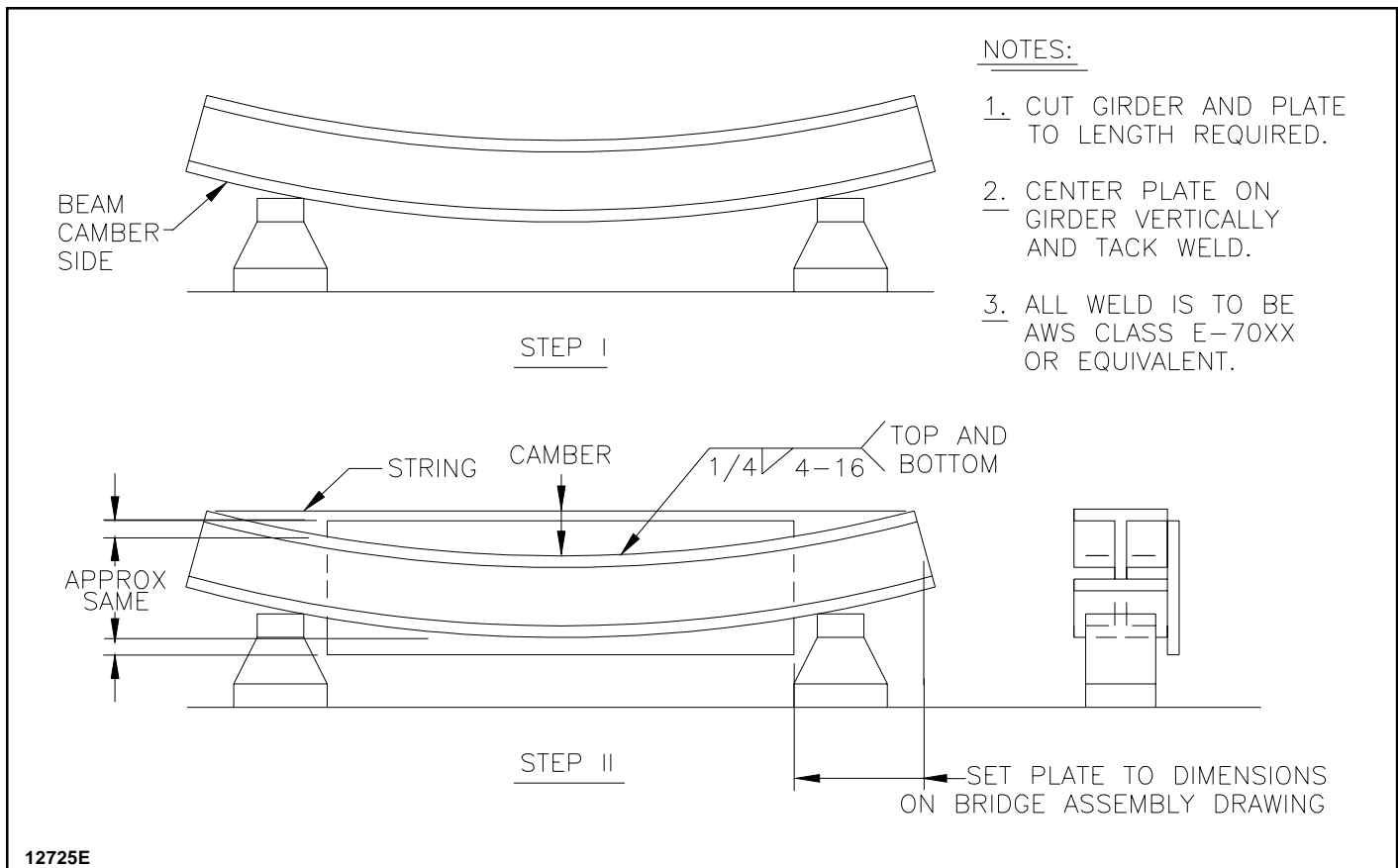
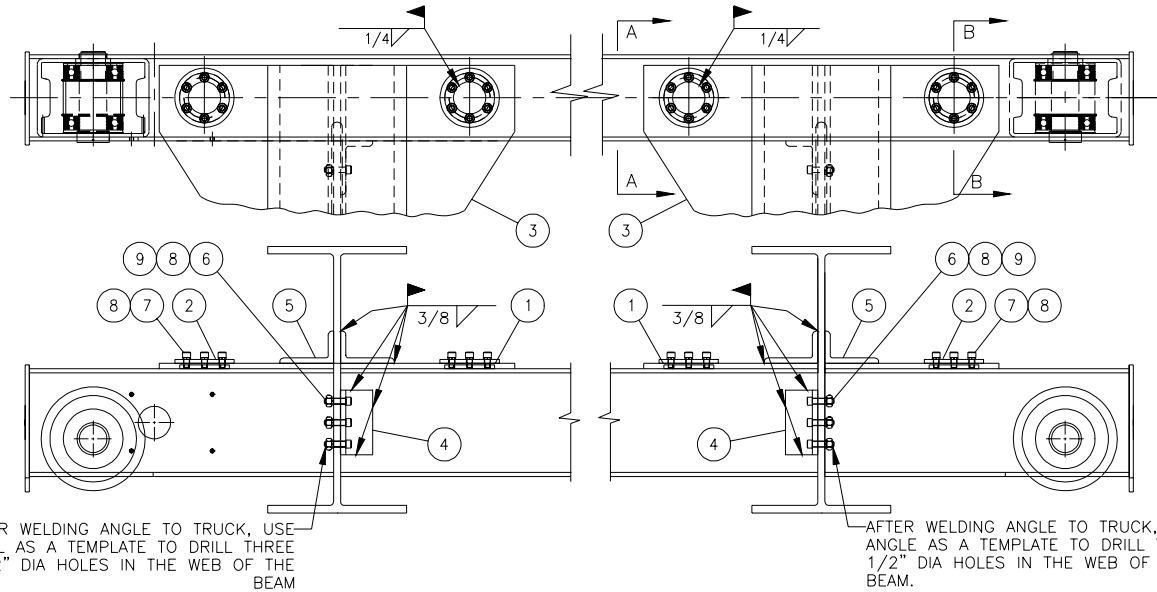
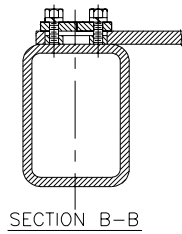
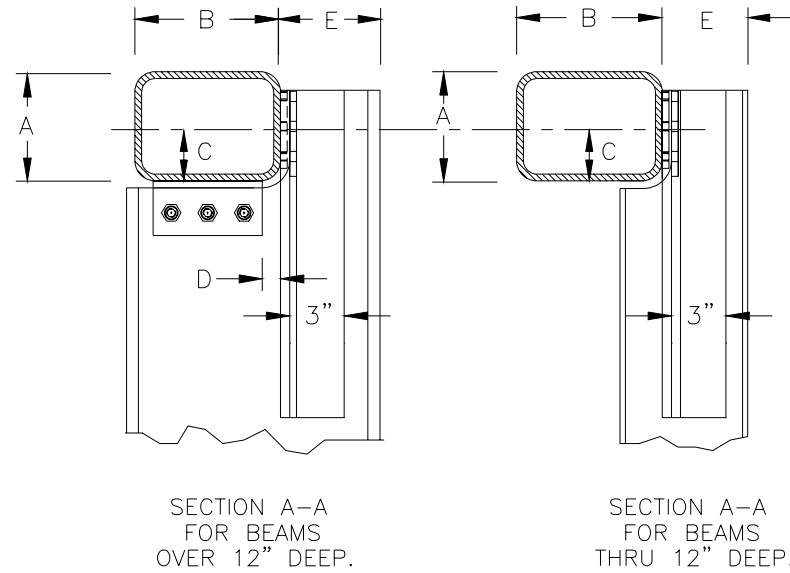

Figure 3.



WHEEL DIAMETER	A	B	C	D
6"	6"	8"	3"	1"
8	8	10	4	2
10	8	12	4	3

NOMINAL BEAM SIZE	E
8 THRU 12	5-1/2"
14 THRU 30	7
36	12



REF. NO.	KEY NUMBER	DESCRIPTION	QTY. REQ'D.
1	TRK-1001	INNER RING	8
2	TRK-1002	CAP	8
3	TRK-1003	GUSSET PLATE 1/2" THICK	4
4	TRK-1004	ANGLE 5 X 3 X 1/2 X 6" LONG	4
5	TRK-1005	ANGLE 5 X 3 X 1/2 X 19" LONG	8
6	TRK-1006	SOCKET HEAD CAP SCREW (PLATED) 1/2-13 X 2	12
7	TRK-1007	SOCKET HEAD CAP SCREWS (PLATED) 1/2-13 X 1	48
8	TRK-1008	HI-COLLAR SPRING LOCKWASHER (PLATED) 1/2	60
9	TRK-1009	SEMI-FINISHED HEAVY HEX NUT 1/2	12

12979C2

Figure 4. Bridge "Whale's Tail" Bolted End Connection

*FOR STANDARD UNITS ONLY

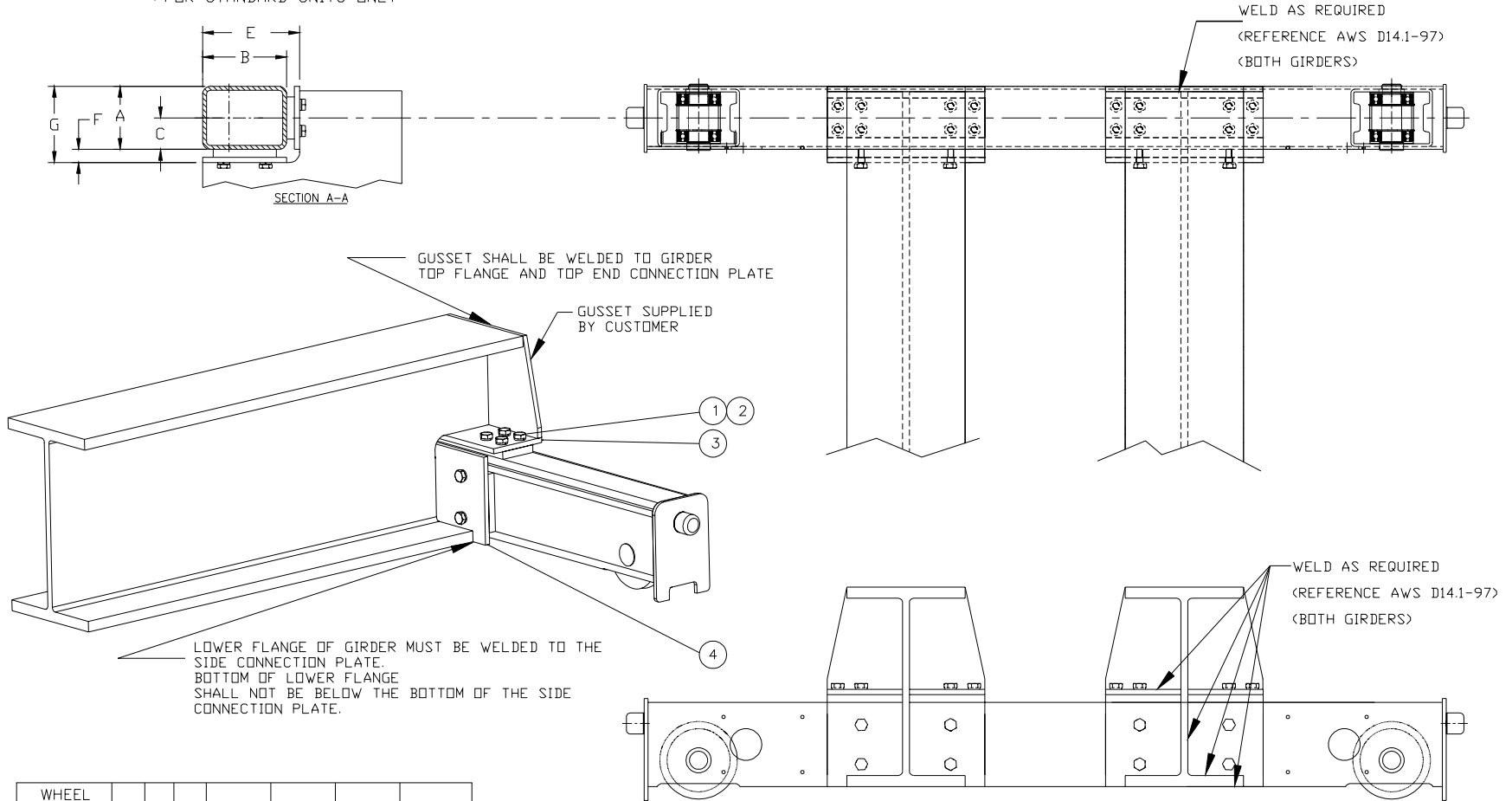

WHEEL DIAMETER	A	B	C	D	E	F	G
6"	6"	8"	3"	1 1/4"	9 1/4"	1 1/4"	7 1/4"
8	8	10	4	1 1/4"	11 1/4"	1 1/4"	9 1/4"
10	8	12	4	1 3/4"	13 3/4"	1 3/4"	9 3/4"

REF. NO.	KEY NUMBER	6" & 8" WHEEL DIAMETER		10" WHEEL DIAMETER		
		DESCRIPTION	QTY. REQ'D.	KEY NUMBER	DESCRIPTION	QTY. REQ'D.
1	TRK-1101	*ASTM A325 5/8-11 BOLTS	24	TRK-1105	*ASTM A325 3/4-10 BOLTS	28
2	TRK-1102	*HI-COLLAR SPRING LOCKWASHER (PLATED) 5/8	24	TRK-1106	*HI-COLLAR SPRING LOCKWASHER (PLATED) 3/4	28
3	TRK-1103	*GRIDER CONNECTION TOP PLATE 1/2" THICK	2	TRK-1107	*GRIDER CONNECTION TOP PLATE 1/2" THICK	2
4	TRK-1104	*GRIDER CONNECTION SIDE PLATE 1/2" THICK	2	TRK-1108	*GRIDER CONNECTION SIDE PLATE 1/2" THICK	2

4B12979

Figure 4B. Bridge Bolted Plate End Connection

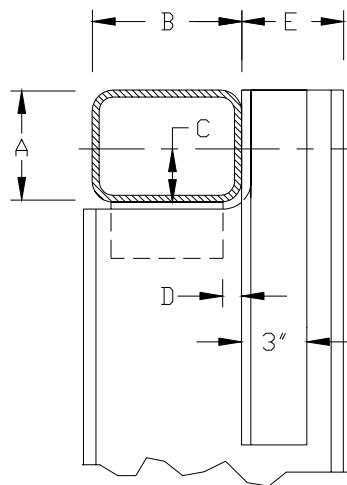

SECTION A-A
FOR BEAMS
OVER 12" DEEP.

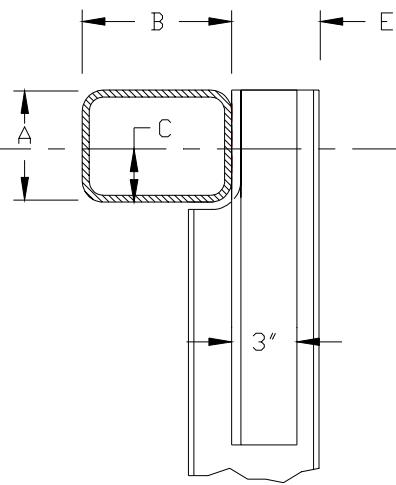

SECTION A-A
FOR BEAMS
THRU 12" DEEP.

WHEEL DIAMETER	A	B	C	D
6"	6"	8"	3"	1"
8	8	10	4	2
10	8	12	4	3

NOMINAL BEAM SIZE	E
8 THRU 12	5-1/2"
14 THRU 30	7
36	12

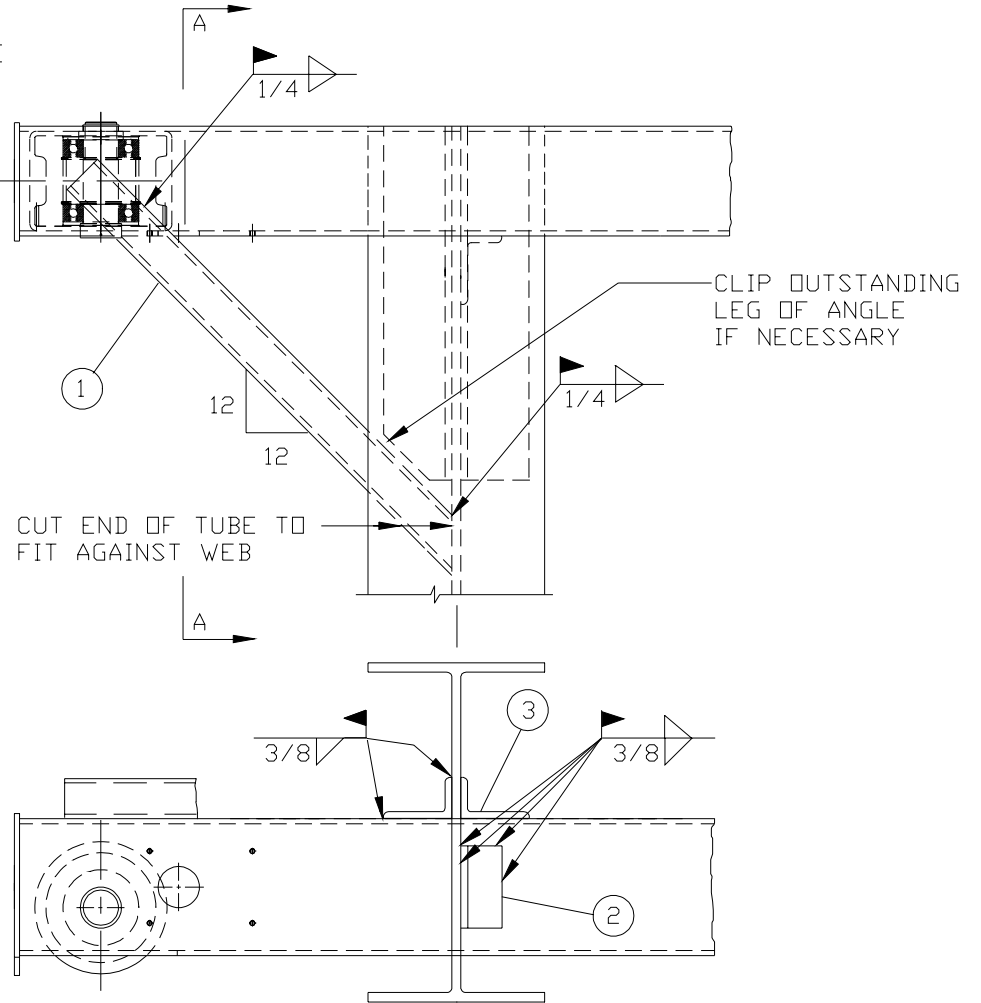

ITEM	DESCRIPTION	QTY. REQ'D.
1	SQUARE TUBE 3 X 3 X 1/4 X AS REQUIRED *	4
2	ANGLE 5 X 3 X 1/2 X 6" LONG	4
3	ANGLE 5 X 3 X 1/2 X 19" LONG	8

* LENGTH IS APPROXIMATELY
.71 TIMES (WHEELBASE - GAGE)

Figure 5. Bridge Welded End Connection

2. Locate end trucks in the notch of the girders, one at each end of the girders. Make certain trucks are level with each other and are level at the four points as shown in Figure 6.

It is quite possible that the bottom flange of the girder is not level even though the top flange is level. **DO NOT LEVEL FROM ROUGH TRUCK STRUCTURE.** Correct operation of the hoist-trolley requires that **the top flanges are level.**

3. To check the distance between the trucks, push all truck wheels toward the center of the span. The distance from the outside of the wheel on one side of the span to the inside of the wheel on the other side of the span should equal the span length for the 8" and 10" diameter wheels. See Figure 7. The tolerance on this distance is $\pm 1/32"$.

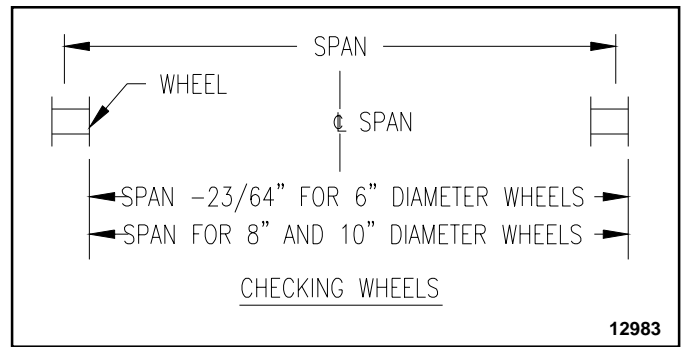

Figure 7.

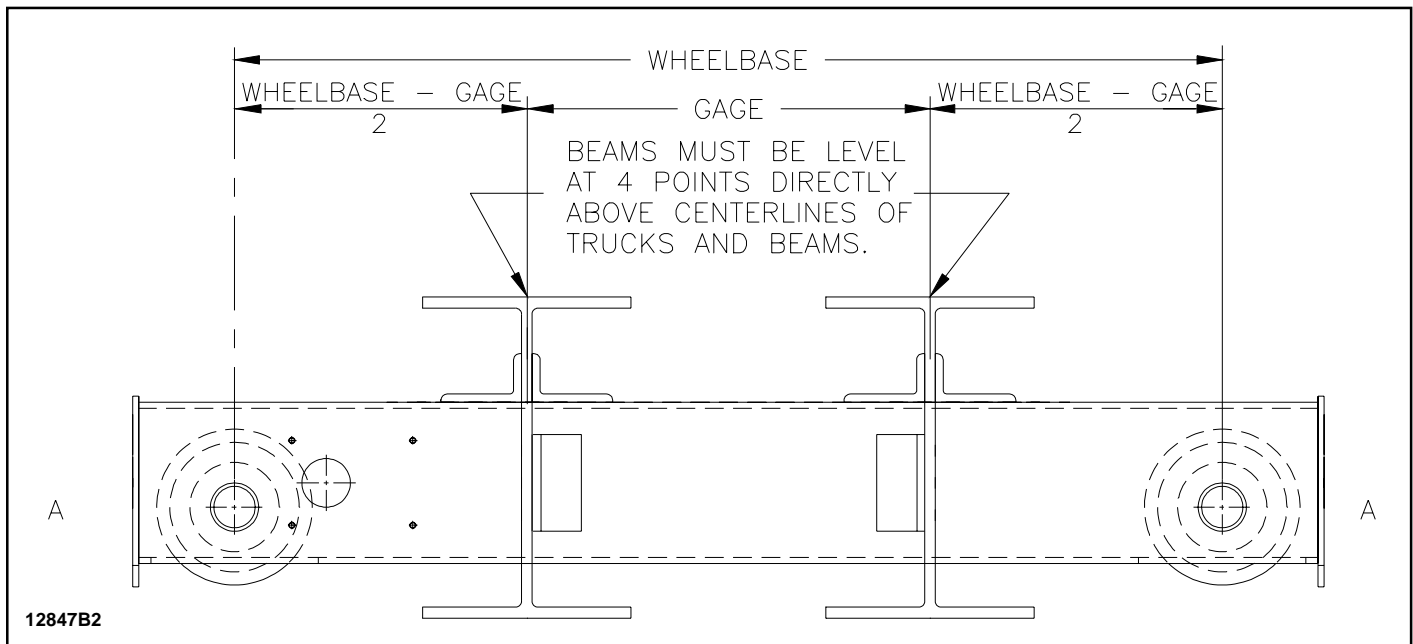

Figure 6.

4. For Squaring Crane there are measuring dimples available on the inside faces of the truck above the axles. To check the squareness, use a spring scale on the end of a steel tape and measure diagonally across the crane. Then measure across the opposite diagonal with the same force on the scale. These dimensions should be within $1/16"$ of each other.

Any other method of squaring the trucks that gives comparable results may be used.

After squaring the trucks double check the span at both ends of the trucks.

5. After assuring that the trucks are accurately positioned and squared, complete girder connections and then proceed to instructions for assembly for the type of crane being built. The girder connections are shown in Figures 4, 4B and 5.

6. For the bolted end connection, first clamp the horizontal gusset plate (Ref. No. 3) to the top of the truck so that the center of the holes is in line with the center of the trucks.

Do not use excessive heat or weld that might cause distortion. Alternate welds as much as possible. Weld the angles (Ref. No. 5), long leg horizontal, to the web of the girder and to the gusset plate. Next, place the rings (Ref. No. 1) in the holes on the gusset plates and weld to the top of the truck. Place the cap (Ref. No. 2) on the inner ring and hold in place with a couple of bolts. Bolt the connection (Ref. Nos. 2, 7 and 8).

7. Position the angle (Ref. No. 4), short leg, against the side of the truck and weld in place. Using the angle as a template drill three $1/2"$ diameter holes in the web of the girder and bolt up (Ref. Nos 6, 8 and 9).

8. For the welded end connection weld the angles (Ref. No. 3), long leg horizontal, to the truck and to the girder web. Position the angle (Ref. No. 2), short leg, against the side of the truck and weld in place to the truck and to the girder web. Weld the brace (Ref. No. 1) in place. All welded connections must have this brace.

WHEEL DIAMETER	A	B	CROSS SHAFT DIAMETER	COUPLING CATALOG NUMBER	PILLOW BLOCK CAT. NO.	C	D	HAND CHAIN WHEEL	HAND CHAIN	E
8"	4-1/4"	8-11/16"	1-3/16"	8280	904625	8-5/16"	4-3/4"	913115	8282	5.680"
10"	4-1/4"	10 3/8"*	1-3/16"	8280	904625	8-5/16"	4-3/4"	332189-3	8282	6.901"

SEE MATERIAL TABLES FOR REQUIRED NUMBER OF CROSS SHAFT BEARINGS AND COUPLINGS.

* 10-7/8" WHEN BUMPER DIAMETER IS 3.2"

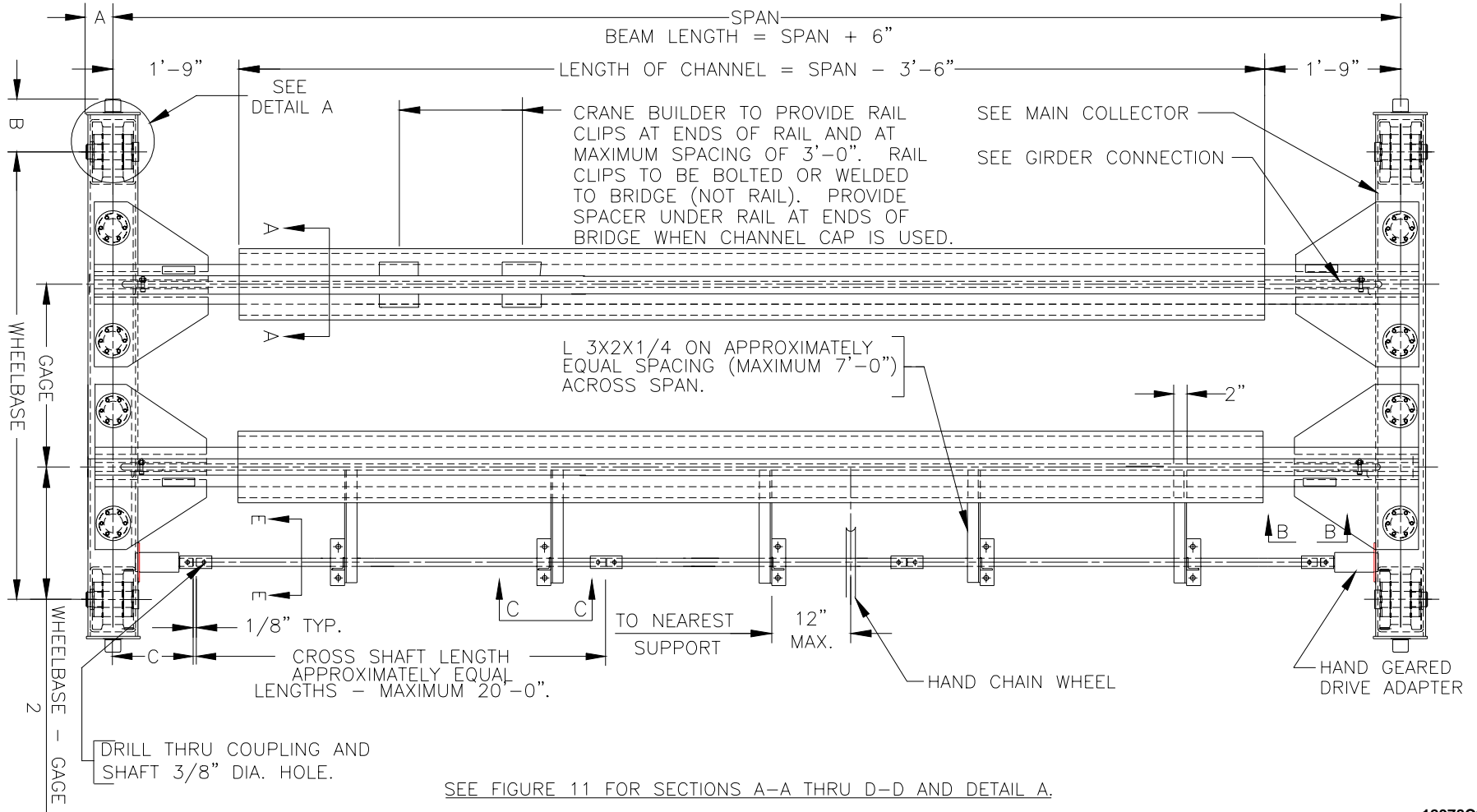

SEE FIGURE 11 FOR SECTIONS A-A THRU D-D AND DETAIL A.

12978C2

Figure 10. Hand Geared Bridge Assembly

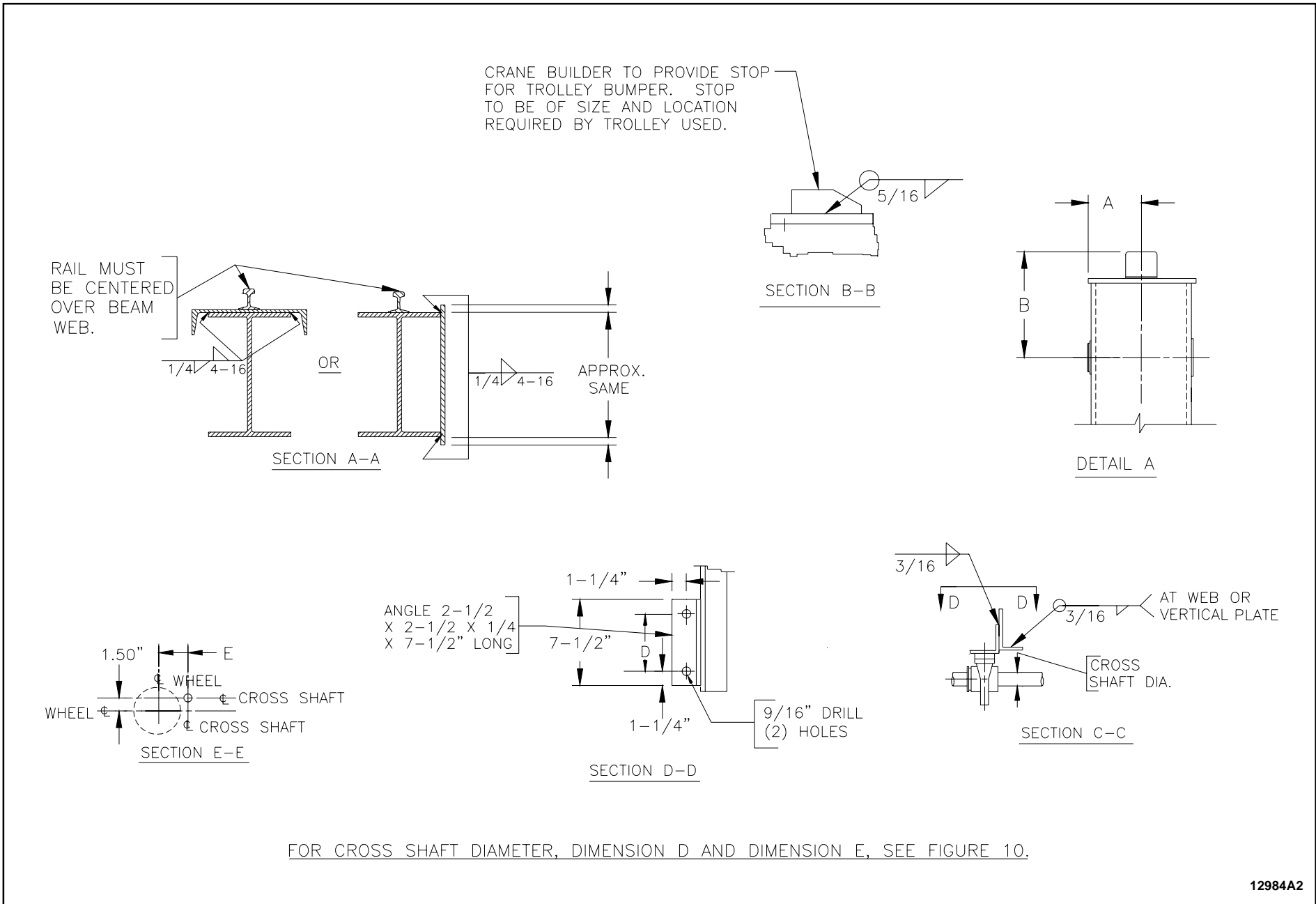

12984A2

Figure 11. Bridge Details

INSTRUCTIONS FOR ASSEMBLING INDIVIDUAL DRIVE CRANE BRIDGES

1. Refer to Figure 9, Motor Driven Bridge Assembly.
2. Prepare bridge girder with capping channel or vertical plate, if required (See Pages 3 and 4).
3. Follow instructions for assembling bridge girder to end trucks as outlined on Pages 4 and 8.
4. The gear case (with wheel pinion), motor and brake are shipped as an assembly. Bolt this assembly to the side of the truck with four socket head cap screws with lockwashers. Install vent plug in place of pipe plug at top of gear case.
5. The electrical enclosure and fused disconnect switch is to be mounted where required by the crane builder. Assure all clearances.
6. Add rails as shown on Figure 9.
7. Locate and weld trolley stops at the ends of the girders as shown on Figure 11. Bumpers must engage trolley stops.

INSTRUCTIONS FOR ASSEMBLING A HAND GEARED CRANE BRIDGE

1. Refer to Figure 10, Hand Geared Bridge Assembly.
2. Prepare bridge girder with capping channel or vertical plate, if required (See Pages 3 and 4).
3. Follow instructions for assembling bridge girder to end trucks as outlined on Pages 4 and 8.
4. Mount and bolt the hand geared drive adapter for the cross shaft to the side of the truck with four socket head cap screws with lockwashers.
5. Locate and tack cross shaft support angles to the girder. Recheck that angles are level and square and finish welding according to Figure 11.
6. Form pillow block supports by mounting the angles together as shown in Section C-C of Figure 11. Mount the pillow blocks to the completed assembly by bolting.
7. Place the proper number of pillow blocks and couplings on each shaft section. Notice that the separate bearing locking collar has a counterbore on one side. This counterbore fits over the protruding inner race of the pillow block bearing. Place locking collar on the shaft properly.
8. Place the hand chain wheel and guide on the appropriate shaft section (near the center of the crane) within 12" of a bearing support. For cranes 10 tonnes and more, a keyway 5/16" x 5/32" needs to be cut into the cross shaft location at the hand chain wheel. Put key in place.
9. Set shafting in place, align pillow blocks to cross shaft support angles and clamp in place.

10. Check horizontal and vertical alignment of the cross shaft by using a taut line. Complete assembly when alignment is assured.

11. Set space between cross shafts to 1/8". Position couplings and drill 3/8" diameter holes through the shaft and coupling using the holes in the coupling as a guide. The coupling has a pre-drilled hole through one side only. The shaft and coupling are then secured by hex head bolts with lockwashers and nuts.

12. Slide bearing locking collars into place next to pillow blocks. Make sure that the counterbore in the collar is fitted over the extended race of the bearing. Fasten to shaft with set screw in locking collar.

13. Add rails as shown on Figure 10.

14. Locate and weld trolley stops at the ends of the girders as shown on Figure 11.

PAINTING

After all welding is completed and prior to installing the cross conductors, wire brush all steel and remove all scale, weld splatter, flux and any other foreign matter. Grease spots are to be cleaned using commercially available solvent. Wash with clear water an area six inches either side of all welds to remove flux residue.

The electrical panel must be closed, and areas such as the switch handle, Off-On identification, wheel gear and pinion, and nameplate, etc., must be masked prior to painting.

Any national brand zinc-rich, chromate primer may be used and applied according to the manufacturer's directions. Final coat is recommended to be high gloss enamel, especially suited for steel surfaces and as recommended by any national brand paint manufacturer. Application must be in accordance with manufacturer's recommendations.

MARKINGS

Codes require that the capacity of the bridge be shown on both sides of the crane, legible from the floor. Normal practice for marking is to use capacity in tons. For example: 1 TON, 2 TON, etc. Stencil forms are readily available that may be used with brush on or spray-can paint. Commercially available block letters and numerals with adhesive backing could also be used. Selection of size should be such that the sign can be easily read from the operating floor.

The builder's name shall also be placed on the crane in a prominent location along with a serial number or other means of crane identification.

NOTICE

The crane builder and user are responsible for marking the crane and also to check for compliance with all local, state and national codes.

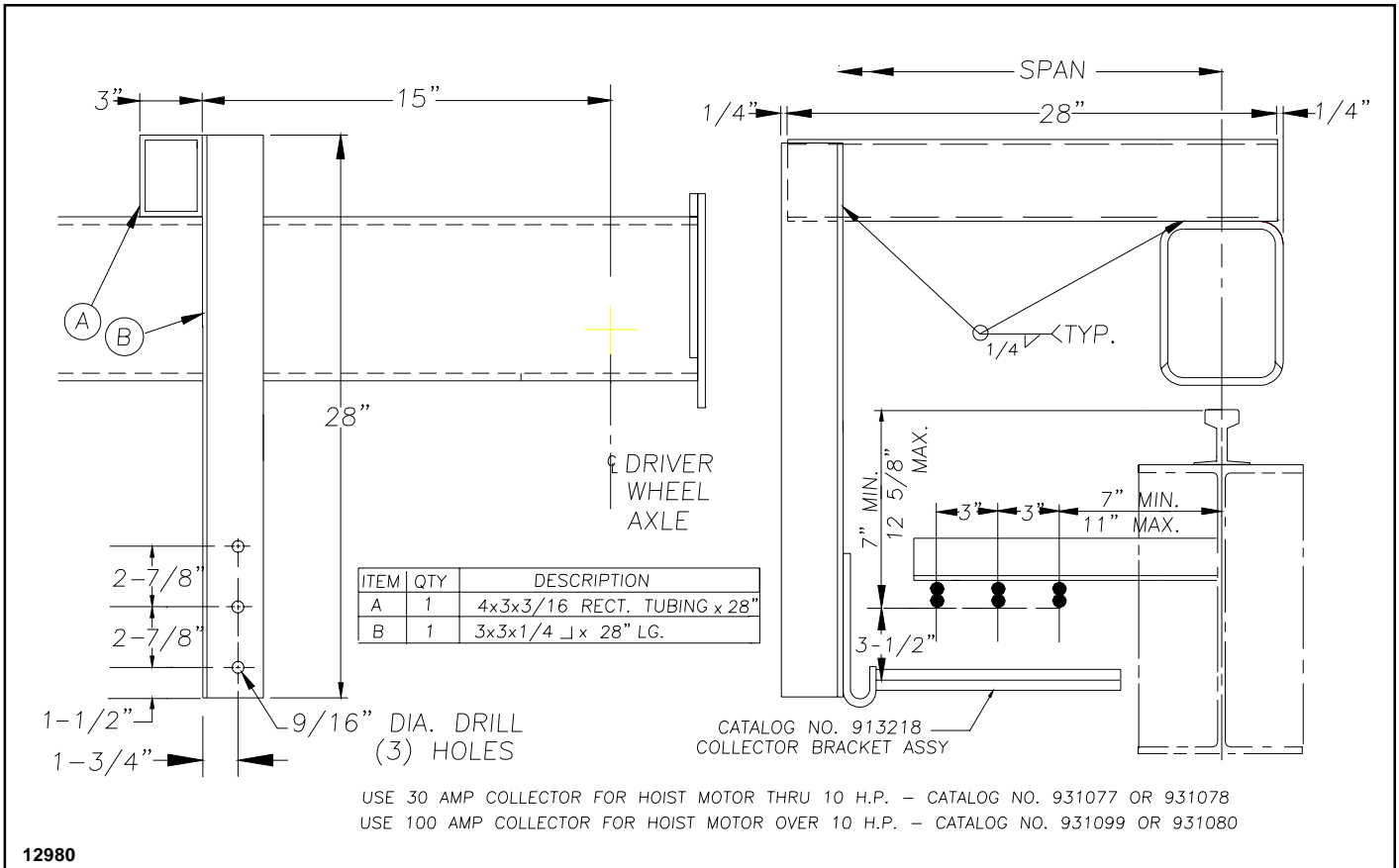

Figure 12. Main Collector Assembly

PUSH BUTTON SYSTEM

The preferred way of operating the controllers on the crane from the floor is a festooned system sold as a kit. This is to be installed as shown in the literature supplied with this system.

CROSS CONDUCTOR SYSTEM

A cross conductor system is a means of providing electric current from the main conductors to the moving hoist-trolley.

The preferred cross conductor system is a festooned system sold as a kit and it is to be installed as shown in the literature supplied with this system.

MAIN COLLECTOR ASSEMBLY

Refer to Figure 12, Main Collector Assembly.

The collectors listed (Catalog Numbers 931077, 931078, 931080 and 931099) are compatible with and will operate only on conductor bars listed as Catalog Numbers for Crane Runways on page 15. The builder must check to ensure that the proper spacing and location of the conductors will clear all obstructions in the building.

⚠ WARNING

Ordinarily the crane is grounded to the runway beam through the contact with the crane wheels. Certain environments may prevent proper grounding by this means. In those cases, a 4th runway conductor and collector should be provided to assure adequate grounding.

This also applies to the cross conductors and the electrical contact between the trolley wheels and the bridge girder.

INSTALLATION OF THE CRANE BRIDGE

Installation of the crane on the runway shall be performed only by a qualified crane installer. For information regarding attaching and lifting or moving the loads during installation, refer to ANSI B30.2 - latest edition, Chapter 2-3 and other applicable codes.

⚠ WARNING

Before installing the crane on the runway, lock the runway conductor disconnect switch in the open (off) position.

Prior to the start of any crane erection the building should be measured for spans of rails and clearances. These measurements should be checked against the corresponding crane measurements to insure correctness of "fit". After assurances that the crane fits the building, determine orientation of the crane position with respect to the runway.

These types of cranes are usually lifted into position on the runway rails in one piece.

Immediately after the crane is placed on the runway rails check wheel flange clearances to the rail. Clearance between side of rail head and inside flange of wheel will vary from 3/8" to 1-1/8" depending on the wheel and rail combination and whether or not the truck is centered on the rail. Total wheel float will not be less than the 3/4" recommended by CMAA Specification #70.

NOTE: It is suggested that the trolley and hoist be installed on the crane bridge at this time so that all wiring connections can be completed.

FUSE AND MAINLINE DISCONNECT PANELS

Mainline disconnect panels and fuse bridge control panels are provided as options to assist users in complying with OSHA codes. When ordering with crane, they will be completely installed inside of electrical enclosures.

Electrical service is to be connected to the crane equipped with fuse panels and mainline disconnect panels as shown in the proper wiring diagram. Wiring diagrams are in Part No. 113533-83, Wiring Diagrams for Bridge Control Panels.

 CAUTION
Power supply must be same voltage, frequency and phase as specified on crane motor nameplate.

LUBRICATION

1. Wheel bearings are permanently lubricated and require no additional lubricant.

2. Drive wheel gears are to be lubricated with an open type gear grease which is heavy, plastic, extreme pressure and tacky; such as MOBILTAC 375 NC or equal.

3. The gear case lubricant should be changed every year or 2000 hours of service for moderate usage. The lubricant should be changed more frequently if the service is more severe. Use one quart of AGMA lubricant number 5, compounded, (Mobilgear 630) if the ambient temperature is 15° to 60°F or AGMA lubricant number 7, compounded, (Mobilgear 634) if the ambient temperature is 50° to 125°F.

4. It is recommended that the areas of the cross shaft covered by bearing and couplings be coated with FEL-PRO C5-A, or equal, anti-seize lubricant.

Before crane operation the vent plug must be in the proper location in the gear case. The vent plug replaces the pipe plug in the highest location on the end of the gear case. See Part No. 113533-82, Operating Instructions and Parts List, Bridge Drive Gear Case, included with this package.

BRAKE

A separate piece of literature in the literature package covers parts and adjustment of the brake.

OPERATION

Prior to placing the crane into service, OSHA requires that the user perform and record certain tests including proof loading the crane. Refer to ANSI B30.2-latest edition for information concerning these requirements.

SPECIFICATIONS

Specifications may be purchased from:

<u>Specification</u>	<u>Address</u>
AGMA	American Gear Manufacturers Association 1500 King Street, Suite 201 Alexandria, VA 22314-2730
ANSI	American National Standards Institute 11 W. 42nd Street, 13th Floor New York, NY 10036
ASCE	American Society of Civil Engineers 1801 Alexander Bell Drive Reston, VA 20191-4400
ASTM	American Society for Testing and Materials 100 Barr Harbor Drive West Conshohocken, PA 19428-2959
AWS	American Welding Society 550 N. W. LeJune Road Miami, FL 33126
CMAA	Material Handling Industry 8720 Red Oak Blvd., Suite 201 Charlotte, NC 28217-3992 (CMAA is Crane Manufacturers Association of America, Inc.)
NFPA	National Fire Protection Association 11 Tracy Drive Avon, MA 02322-9908
OSHA	Superintendent of Documents U.S. Government Printing Office Washington, DC 20402 (OSHA is Title 29 CFR Parts 1901.1 to 1910.999)

MATERIAL LISTED BELOW IS REQUIRED TO BUILD THESE BRIDGE CRANES

THESE TRUCKS ARE COMMON TO ALL BRIDGES

End Truck Assembly (One Right and One Left Hand Truck)					
Rated Load Range (tonnes)	For Spans Thru (ft)	Catalog Number	Wheel Base	Whl. Dia. (in)	Min. Rail (#/yd.)
1 thru 15	52	TRFA0807.5AR3	7' - 6"	8	30
	60	TRFA0809.0AR3	9' - 0"	8	30
	60	TRFA0810.5AR3	10' - 6"	8	30
1 thru 15	52	TRFA0807.5BR3	7' - 6"	8	60
	60	TRFA0809.0BR3	9' - 0"	8	60
	60	TRFA0810.5BR3	10' - 6"	8	60
15 thru 25	52	TRFA1007.5AR4	7' - 6"	10	30
	60	TRFA1009.0AR4	9' - 0"	10	30
	60	TRFA1010.5AR4	10' - 6"	10	30
15 thru 25	52	TRFA1007.5BR4	7' - 6"	10	60
	60	TRFA1009.0BR4	9' - 0"	10	60
	60	TRFA1010.5BR4	10' - 6"	10	60

With 3.2" diameter bumpers.

Bumpers and rail sweeps are standard.

The wheelbase of the end truck shall be 1/7 of the span or greater - per CMAA 70.

HAND GEARED BRIDGE COMPONENTS

Rated Load Range (Tonnes)	For Spans Thru (ft)	Cross Shaft Bearing Ass'y		Cross Shaft Coupling		Hand Chain Wheel and Guide 1 Ass'y Req'd	Hand Chain with Open Link (36 feet)
		Number Req'd	Catalog Number	Number Req'd	Catalog Number		
1 thru 10	12	1		2		913115	8282
	22	2		2			
	28	3		3			
	36	4	904625	3	8280		
	42	5		4			
	60	7		4			
10 thru 15	12	1		2		332189-3	8282
	22	2		2			
	28	3		3			
	36	4	904625	3	8280		
	42	5		4			
	60	7		4			

1 End Truck Assembly - See Truck Chart.

1 Pair of Hand Geared Drive Adapter Assemblies Per Truck Assembly (1 Req'd. per Crane): Catalog Number 229984-1.

CATALOG NUMBERS REQUIRED FOR OPTIONAL EQUIPMENT

Festoon Systems

Description	Catalog Numbers for Bridge Span of				
	20'	30'	40'	50'	60'
Cross Conductors*	931089	931090	931091	931092	931093
Push Button (2) #16-8C	931104	911305	931106	931107	931108

*12 Conductor - Flat Cable (#14-4C & #16-8C)
#14 Power Cable Good for 10 HP @ 460V or 5 HP @ 230V (20 Amps).

Main Collectors

Description	Catalog Number
Collector Pole & Bracket	901590
30A Main Collectors Short Arm Long Arm	931077 931078
100A Main Collectors Short Arm Long Arm	931099 931080

Catalog Number for Bolted Bridge End Connection: 444697-10

90A Insulated Figure 8 Runway Conductors.

Description	Catalog Number for Span of							
	50'	60'	70'	80'	90'	100'	150'	200'
Crane Runway Kit	931119	931120	931121	931122	931123	931124	931125	931126

MATERIAL LISTED BELOW IS REQUIRED TO BUILD THESE BRIDGE CRANES

INDIVIDUAL DRIVE - MOTOR DRIVEN BRIDGE COMPONENTS

One Drive Assembly includes Two Motor, Brake and Reducer Assemblies

1 Speed - VFC Motors

Traverse Gear Cases

Motor HP	Motor RPM	200V, 3Ph, 60Hz		230/460V, 3Ph, 60Hz		575V, 3Ph, 60Hz	
		Motor Cat. No.	Brake Cat. No.	Motor Cat. No.	Brake Cat. No.	Motor Cat. No.	Brake Cat. No.
1/2	1200	331981-57	108461-F1	331981-58	108461-F1	331981-59	108461-F2
3/4	1200	331981-77	913314	331981-78	913314	331981-79	913315
1	1200	331981-42	913314	331981-43	913314	331981-44	913315
1/2	1800	331981-52	108461-F1	331981-53	108461-F1	331981-54	108461-F2
3/4	1800	331981-72	108461-F1	331981-73	108461-F1	331981-74	108461-F2
1	1800	331981-02	108461-F1	331981-03	108461-F1	331981-04	108461-F2
1-1/2	1800	329925-11	913314	329925-11	913314	329925-12	913315
2	1800	329925-21	913316	329925-21	913316	329925-22	913317
3	1800	329925-31	913316	329925-31	913316	329925-32	913317

Traverse Gear Case Cat. No.	Gear Ratio	Bridge FPM with 1200 RPM Motor	Bridge FPM with 1800 RPM Motor
444689-1	13.04	50	75
444689-2	8.96	Not Used	100
444689-3	6.97	Not Used	125
444689-4	6.08	Not Used	150

2 Speed Motors

Motor HP	Motor RPM	200V, 3Ph, 60Hz		230V, 3Ph, 60Hz		460V, 3Ph, 60Hz		575V, 3Ph, 60Hz	
		Motor Cat. No.	Brake Cat. No.	Motor Cat. No.	Brake Cat. No.	Motor Cat. No.	Brake Cat. No.	Motor Cat. No.	Brake Cat. No.
.5/.25	1200/600	331982-56	108461-F1	331982-57	108461-F1	331982-58	108461-F1	331982-59	108461-F2
.75/.38	1200/600	331982-76	913314	331982-77	913314	331982-78	913314	331982-79	913315
1/5	1200/600	331982-41	913314	331982-42	913314	331982-43	913314	331982-44	913315
.5/.17	1800/600	331982-51	108461-F1	331982-52	108461-F1	331982-53	108461-F1	331982-54	108461-F2
.75/.25	1800/600	331982-71	108461-F1	331982-72	108461-F1	331982-73	108461-F1	331982-74	108461-F2
1/.33	1800/600	331982-01	108461-F1	331982-02	108461-F1	331982-03	108461-F1	331982-04	108461-F2
1.5/.5	1800/600	330031-11	913314	330031-12	913314	330031-13	913314	330031-14	913315
2/.67	1800/600	330031-21	913316	330031-22	913316	330031-23	913316	330031-24	913317
3/1	1800/600	330031-31	913316	330031-32	913316	330031-33	913316	330031-34	913317

Controls (All 3Ph, 60Hz) (NA = Not Available or Not Applicable)

Total HP	200V		230V		460V		575V	
	Control	D.B.R.	Control	D.B.R.	Control	D.B.R.	Control	D.B.R.
Variable Frequency Control								
1	448550-11	448491-31	448550-21	448491-31	448550-42	448491-62	445351-52	444946-E1
2	448550-12	448491-32	448550-22	448491-32	448550-42	448491-62	445351-52	444946-E1
3	448550-13	448491-33	448550-23	448491-33	448550-43	448491-63	445351-53	444946-E2
5	448550-15	448491-34	448550-25	448491-34	448550-45	448491-64	445351-55	444946-E3
7.5	448550-17	444946-64	448550-27	444946-64	448550-47	444946-79	445351-57	444946-E4
10	448550-19	444946-65	448550-29	444946-65	448550-49	444946-80	445351-59	444946-E5

Total HP	200V	230V	460V	575V	Total HP	200V	230V	460V	575V
1 Speed Control - without Soft Start					1 Speed Control - with Soft Start				
1	444231-11	444231-21	444231-41	444231-51	1	444711-11	444711-21	444711-41	444711-51
2	444231-12	444231-22	444231-42	444231-52	2	444711-12	444711-22	444711-42	444711-52
3	444231-13	444231-23	444231-43	444231-53	3	444711-13	444711-23	444711-43	444711-53
5	444231-15	444231-25	444231-45	444231-55	5	444711-15	444711-25	444711-45	444711-55
7.5	444231-17	444231-27	444231-47	444231-57	7.5	NA	NA	444711-47	444711-57
10	444231-19	444231-29	444231-49	444231-59	10	NA	NA	444711-49	444711-59
2 Speed Control - without Soft Start					2 Speed Control - with Soft Start				
1	444232-11	444232-21	444232-41	444232-51	1	444712-11	444712-21	444712-41	444712-51
2	444232-12	444232-22	444232-42	444232-52	2	444712-12	444712-22	444712-42	444712-52
3	444232-13	444232-23	444232-43	444232-53	3	444712-13	444712-23	444712-43	444712-53
5	444232-15	444232-25	444232-45	444232-55	5	444712-15	444712-25	444712-45	444712-55
7.5	444232-17	444232-27	444232-47	444232-57	7.5	NA	NA	444712-47	444712-57
10	444232-19	444232-29	444232-49	444232-59	10	NA	NA	444712-49	444712-59

BEAM SIZE SELECTION FOR VARIOUS SPANS

ENGLISH MEASURE (TONS)

SERIES 700 TROLLEY KIT

1. Section designation is in accordance with AISC.
2. Beam sizes listed are American standard (S) beams, wide flange (W) and channel (C) sections and plate (PL).
3. Use ASTM A 36 grade steel, first quality, free of rust and excessive mill scale.
4. The bridge is designed in accordance with CMAA Specification 70, revised 1994 and is based on the following assumptions:

Rated Load	Trolley Load	Reeved	Gage
5 Ton	2485#	Single	78"
7-1/2	2485	Single	78
10	4385	Single	78
15	4465	Single	78
20	5165	Single	78
25	5165	Single	78

Tons are short tons.

DLFB, DLFT, HLF and IFD are assumed to be 1.1, 1.1, .15 and .1 respectively.

Bridge speed is assumed to be 150 FPM.

Bridge class of service is assumed to be C.

Assumed additional dead load is 10 #/ for both front and back girders.

The bridge is assumed to be an indoor bridge.

5. If any of the above assumptions are exceeded contact the factory for girder selection.

6. No additional loading such as footwalks, platforms, cabs, machinery, etc., is allowed.

Span Thru (ft)	W	Ww/C		Ww/PL	
		W	C	W	PL
7-1/2 TON RATED LOAD					
20	14X 48	14X 30	10X 15.3	12X 40	14X .2500
22	14X 53	16X 36	10X 15.3	16X 36	18X .3125
24	14X 61	16X 36	10X 15.3	16X 36	18X .3125
26	16X 67	16X 36	10X 15.3	18X 50	20X .3125
28	16X 67	18X 50	10X 15.3	18X 50	20X .3125
30	16X 77	18X 50	10X 15.3	18X 50	20X .3125
32	16X 77	18X 50	10X 15.3	18X 50	20X .3125
34	16X 89	18X 60	12X 20.7	21X 62	23X .3750
36	16X100	18X 60	12X 20.7	21X 62	23X .3750
38	16X 100	21X 62	12X 20.7	21X 62	23X .3750
40	33X 130	21X 62	12X 20.7	21X 62	23X .3750
42	30X 132	21X 62	12X 20.7	24X 68	26X .5000
44	36X 150	21X 68	12X 20.7	24X 68	26X .5000
46	33X 152	24X 62	15X 33.9	24X 68	26X .5000
48	36X 170	24X 62	15X 33.9	24X 68	26X .5000
50	36X 170	27X 68	15X 33.9	24X 68	26X .5000
52	36X 182	24X 76	15X 33.9	27X 84	29X .5000
54	36X 194	24X 76	15X 33.9	27X 84	29X .5000
56	36X 210	24X 84	15X 33.9	27X 84	29X .5000
58	36X 210	27X 84	18X 42.7	27X 84	29X .5000
60	36X 232	27X 84	18X 42.7	27X 84	29X .5000

Span Thru (ft)	W	Ww/C		Ww/PL	
		W	C	W	PL
5 TON RATED LOAD					
20	14X 43	12X 26	9X 13.4	14X 30	16X .2500
22	14X 43	12X 26	9X 13.4	14X 30	16X .2500
24	14X 48	14X 30	9X 13.4	14X 30	16X .2500
26	14X 53	14X 30	10X 15.3	16X 36	18X .3125
28	14X 61	16X 36	10X 15.3	16X 36	18X .3125
30	14X 61	16X 36	10X 15.3	16X 36	18X .3125
32	16X 67	16X 36	12X 20.7	18X 50	20X .3125
34	16X 67	18X 50	10X 15.3	18X 50	20X .3125
36	16X 77	18X 50	10X 15.3	18X 50	20X .3125
38	16X 77	18X 50	10X 15.3	18X 50	20X .3125
40	16X 89	18X 50	12X 20.7	21X 62	23X .3750
42	16X 89	18X 60	12X 20.7	21X 62	23X .3750
44	16X 100	21X 62	12X 20.7	21X 62	23X .3750
46	30X 132	21X 62	12X 20.7	21X 62	23X .3750
48	33X 141	21X 62	12X 20.7	21X 62	23X .3750
50	33X 152	21X 68	12X 20.7	24X 68	26X .5000
52	33X 152	21X 62	15X 33.9	24X 68	26X .5000
54	36X 170	24X 62	15X 33.9	24X 68	26X .5000
56	36X 182	24X 62	15X 33.9	24X 68	26X .5000
58	36X 182	24X 68	15X 33.9	24X 68	26X .5000
60	36X 194	24X 68	15X 33.9	21X 101	23X .3750

Span Thru (ft)	W	Ww/C		Ww/PL	
		W	C	W	PL
10 TON RATED LOAD					
20	14X 61	16X 36	12X 20.7	12X 53	14X .3125
22	14X 61	18X 50	10X 15.3	18X 50	20X .3125
24	16X 67	18X 50	10X 15.3	18X 50	20X .3125
26	16X 77	18X 50	10X 15.3	18X 50	20X .3125
28	16X 77	18X 50	10X 15.3	16X 67	18X .3125
30	16X 89	18X 60	12X 20.7	21X 62	23X .3750
32	16X 100	18X 60	12X 20.7	21X 62	23X .3750
34	24X 104	21X 62	12X 20.7	21X 62	23X .3750
36	30X132	21X 62	12X 20.7	21X 62	23X .3750
38	33X 141	21X 68	12X 20.7	24X 68	26X .5000
40	33X 152	24X 62	15X 33.9	24X 68	26X .5000
42	36X 160	24X 62	15X 33.9	24X 68	26X .5000
44	36X 170	24X 68	15X 33.9	24X 68	26X .5000
46	36X 182	24X 76	15X 33.9	27X 84	29X .5000
48	36X 194	24X 84	15X 33.9	27X 84	29X .5000
50	36X 194	27X 84	15X 33.9	27X 84	29X .5000
52	36X 210	27X 84	18X 42.7	27X 84	29X .5000
54	36X 232	27X 84	18X 42.7	30X 99	32X .5000
56	36X 232	27X 84	18X 42.7	30X 99	32X .5000
58	36X 232	27X 94	18X 42.7	30X 99	32X .5000
60	36X 256	27X 94	18X 51.9	30X 99	32X .5000

ENGLISH MEASURE (TONS) SERIES 700 TROLLEY KIT

Span Thru (ft)	W	Ww/C		Ww/PL	
		W	C	W	PL
15 TON RATED LOAD					
20	16X 67	18X 50	10X 15.3	18X 50	20X .3125
22	16X 77	24X 62	10X 15.3	16X 67	18X .3125
24	16X 77	24X 62	10X 15.3	16X 67	18X .3125
26	16X 89	21X 62	12X 20.7	21X 62	23X .3750
28	16X 100	21X 62	12X 20.7	21X 62	23X .3750
30	33X 130	21X 68	12X 20.7	24X 68	26X .5000
32	33X 141	21X 73	12X 20.7	24X 68	26X .5000
34	33X 152	24X 76	12X 20.7	24X 68	26X .5000
36	33X 152	24X 68	15X 33.9	24X 68	26X .5000
38	36X 170	24X 76	15X 33.9	21X 101	23X .3750
40	36X 182	24X 76	15X 33.9	27X 84	29X .5000
42	36X 194	27X 84	15X 33.9	27X 84	29X .5000
44	36X 210	27X 84	15X 33.9	27X 84	29X .5000
46	36X 210	27X 84	18X 42.7	30X 99	32X .5000
48	36X 232	27X 94	18X 42.7	30X 99	32X .5000
50	36X 232	30X 99	18X 42.7	30X 99	32X .5000
52	36X 256	30X 99	18X 51.9	30X 99	32X .5000
54	36X 256	30X 99	18X 51.9	33X 118	35X .6250
56	36X 256	30X 124	18X 42.7	33X 118	35X .6250
58	36X 260	30X 116	18X 51.9	33X 118	35X .6250
60	36X 260	30X 124	18X 58.0	33X 118	35X .6250

Span Thru (ft)	W	Ww/C		Ww/PL	
		W	C	W	PL
25 TON RATED LOAD					
20	16X 89	18X 65	12X 20.7	21X 62	23X .3750
22	16X 89	21X 68	12X 20.7	18X 76	20X .3125
24	16X 100	21X 73	12X 20.7	24X 68	26X .5000
26	33X 130	24X 76	12X 20.7	24X 68	26X .5000
28	33X 141	24X 76	12X 20.7	24X 68	26X .5000
30	33X 152	24X 84	12X 20.7	21X 101	23X .3750
32	36X 170	24X 94	12X 20.7	21X 101	23X .3750
34	36X 182	27X 84	15X 33.9	27X 84	29X .5000
36	36X 182	27X 84	15X 33.9	27X 84	29X .5000
38	36x 194	27X 94	15X 33.9	30X 99	32X .5000
40	36X 210	27X 94	18X 42.7	30X 99	32X .5000
42	36X 232	30X 99	18X 42.7	30X 99	32X .5000
44	36X 232	30X 99	18X 42.7	33X 118	35X .6250
46	36X 232	30X 99	18X 51.9	33X 118	35X .6250
48	36X 256	30X 116	18X 42.7	33X 118	35X .6250
50	36X 256	30X 124	18X 42.7	33X 118	35X .6250
52	36X 260	33X 118	18X 51.9	33X 118	35X .6250
54	36X 260	33X 130	18X 58.0	33X 118	35X .6250
56	36X 260	33X 130	18X 58.0	36X 150	38X .6250
58	36X 280	33X 130	18X 58.0	36X 150	38X .6250
60	36X 280	33X 141	18X 58.0	36X 150	38X .6250

Span Thru (ft)	W	Ww/C		Ww/PL	
		W	C	W	PL
20 TON RATED LOAD					
20	16X 77	16X 57	12X 20.7	16X 67	18X .3125
22	16X 77	18X 60	12X 20.7	16X 67	18X .3125
24	16X 89	21X 62	12X 20.7	21X 62	23X .3750
26	16X 100	21X 62	12X 20.7	21X 62	23X .3750
28	24X 104	21X 68	12X 20.7	24X 68	26X .5000
30	30X 132	24X 68	12X 20.7	24X 68	26X .5000
32	36X 150	24X 76	12X 20.7	24X 68	26X .5000
34	33X 152	24X 84	12X 20.7	21X 101	23X .3750
36	36X 170	24X 76	15X 33.9	27X 84	29X .5000
38	36X 182	24X 84	15X 33.9	27X 84	29X .5000
40	36X 194	27X 84	15X 33.9	27X 84	29X .5000
42	36X 210	27X 84	15X 33.9	27X 84	29X .5000
44	36X 210	27X 84	18X 42.7	30X 99	32X .5000
46	36X 232	27X 94	18X 42.7	30X 99	32X .5000
48	36X 232	30X 99	18X 42.7	30X 99	32X .5000
50	36X 232	30X 99	18X 51.9	33X 118	35X .6250
52	36X 256	30X 99	18X 51.9	33X 118	35X .6250
54	36X 256	30X 124	18X 42.7	33X 118	35X .6250
56	36X 260	30X 116	18X 51.9	33X 118	35X .6250
58	36X 260	30X 124	18X 58.0	33X 118	35X .6250
60	36X 260	33X 130	18X 58.0	33X 118	35X .6250

BEAM SIZE SELECTION FOR VARIOUS SPANS

ENGLISH MEASURE (TONS)

DMR-3 TROLLEYS

1. Section designation is in accordance with AISC.
2. Beam sizes listed are American standard (S) beams, wide flange (W) and channel (C) sections and plate (PL).
3. Use ASTM A 36 grade steel, first quality, free of rust and excessive mill scale.
4. The bridge is designed in accordance with CMAA Specification 70, revised 1994 and is based on the following assumptions:

Rated Load	Trolley Load	Gage
7-1/2 Ton	5000#	72"
10	5000	72
15	5310	84
20	5410	84
25	5710	84

Tons are short tons.

DLFB, DLFT, HLF and IFD are assumed to be 1.1, 1.1, .15 and .1 respectively.

Bridge speed is assumed to be 150 FPM.

Bridge class of service is assumed to be C.

Assumed additional dead load is 10 #/ for both front and back girders.

The bridge is assumed to be an indoor bridge.

5. If any of the above assumptions are exceeded contact the factory for girder selection.

6. No additional loading such as footwalks, platforms, cabs, machinery, etc., is allowed.

Span Thru (ft)	W	Ww/C		Ww/PL	
		W	C	W	PL
10 TON RATED LOAD					
20	14X 48	14X 30	12X 20.7	16X 36	18X .3125
22	14X 53	16X 36	10X 15.3	16X 36	18X .3125
24	14X 61	16X 36	10X 15.3	16X 36	18X .3125
26	16X 67	16X 36	12X 20.7	18X 50	20X .3125
28	16X 67	18X 50	10X 15.3	18X 50	20X .3125
30	16X 77	18X 50	10X 15.3	18X 50	20X .3125
32	16X 77	18X 50	10X 15.3	16X 67	18X .3125
34	16X 89	18X 60	12X 20.7	21X 62	23X .3750
36	16X 100	21X 62	12X 20.7	21X 62	23X .3750
38	24X 104	21X 62	12X 20.7	21X 62	23X .3750
40	30X 132	21X 62	12X 20.7	21X 62	23X .3750
42	33X 141	21X 68	12X 20.7	24X 68	26X .5000
44	36X 150	21X 73	12X 20.7	24X 68	26X .5000
46	33X 152	24X 62	15X 33.9	24X 68	26X .5000
48	36X 170	24X 68	15X 33.9	24X 68	26X .5000
50	36X 170	24X 68	15X 33.9	21X 101	23X .3750
52	36X 182	24X 76	15X 33.9	27X 84	29X .5000
54	36X 194	24X 84	15X 33.9	27X 84	29X .5000
56	36X 210	27X 84	15X 33.9	27X 84	29X .5000
58	36X 210	27X 84	18X 42.7	27X 84	29X .5000
60	36X 232	27X 84	18X 42.7	30X 99	32X .5000

Span Thru (ft)	W	Ww/C		Ww/PL	
		W	C	W	PL
7-1/2 TON RATED LOAD					
20	14X 43	14X 30	9X 13.4	14X 30	16X .2500
22	14X 48	14X 30	9X 13.4	14X 30	16X .2500
24	14X 53	14X 30	10X 15.3	16X 36	18X .3125
26	14X 61	16X 36	10X 15.3	16X 36	18X .3125
28	14X 61	16X 36	10X 15.3	16X 36	18X .3125
30	14X 67	18X 50	10X 15.3	18X 50	20X .3125
32	16X 77	18X 50	10X 15.3	18X 50	20X .3125
34	16X 77	18X 50	10X 15.3	18X 50	20X .3125
36	16X 77	18X 50	10X 15.3	16X 67	18X .3125
38	16X 89	18X 60	12X 20.7	21X 62	23X .3750
40	16X100	18X 60	12X 20.7	21X 62	23X .3750
42	24X 104	21X 62	12X 20.7	21X 62	23X .3750
44	30X 132	21X 62	12X 20.7	21X 62	23X .3750
46	33X 141	21X 68	12X 20.7	24X 68	26X .5000
48	33X 152	21X 73	12X 20.7	24X 68	26X .5000
50	33X 152	24X 62	15X 33.9	24X 68	26X .5000
52	36X 170	24X 62	15X 33.9	24X 68	26X .5000
54	36X 182	24X 68	15X 33.9	24X 68	26X .5000
56	36X 182	24X 68	15X 33.9	21X 101	23X .3750
58	36X 194	24X 76	15X 33.9	27X 84	29X .5000
60	36X 210	24X 84	15X 33.9	27X 84	29X .5000

Span Thru (ft)	W	Ww/C		Ww/PL	
		W	C	W	PL
15 TON RATED LOAD					
20	14X 61	14X 43	12X 20.7	18X 50	20X .3125
22	16X 67	18X 50	10X 15.3	18X 50	20X .3125
24	16X 67	18X 50	10X 15.3	18X 50	20X .3125
26	16X 77	18X 50	10X 15.3	18X 50	20X .3125
28	16X 77	18X 50	12X 20.7	16X 67	18X .3125
30	16X 89	18X 60	12X 20.7	21X 62	23X .3750
32	16X 100	21X 62	12X 20.7	21X 62	23X .3750
34	24X 104	21X 62	12X 20.7	21X 62	23X .3750
36	30X 132	21X 68	12X 20.7	24X 68	26X .5000
38	33X 141	21X 73	12X 20.7	24X 68	26X .5000
40	33X 152	24X 62	15X 33.9	24X 68	26X .5000
42	36X 170	24X 68	15X 33.9	24X 68	26X .5000
44	36X 170	24X 76	15X 33.9	27X 84	29X .5000
46	36X 182	24X 84	15X 33.9	27X 84	29X .5000
48	36X 194	27X 84	15X 33.9	27X 84	29X .5000
50	36X 210	27X 84	15X 33.9	27X 84	29X .5000
52	36X 210	27X 84	18X 42.7	30X 99	32X .5000
54	36X 232	27X 84	18X 42.7	30X 99	32X .5000
56	36X 232	27X 84	18X 42.7	30X 99	32X .5000
58	36X 232	30X 99	18X 42.7	30X 99	32X .5000
60	36X 256	30X 99	18X 42.7	33X 118	35X .6250

ENGLISH MEASURE (TONS) DMR-3 TROLLEYS

Span Thru (ft)	W	Ww/C		Ww/PL	
		W	C	W	PL
20 TON RATED LOAD					
20	16X 67	18X 50	10X 15.3	18X 50	20X .3125
22	16X 77	18X 50	12X 20.7	16X 67	18X .3125
24	16X 77	24X 62	10X 15.3	16X 67	18X .3125
26	16X 89	18X 60	12X 20.7	21X 62	23X .3750
28	16X 100	21X 62	12X 20.7	21X 62	23X .3750
30	24X 104	21X 62	12X 20.7	24X 68	26X .5000
32	30X 132	21X 68	12X 20.7	24X 68	26X .5000
34	33X 141	21X 73	12X 20.7	24X 68	26X .5000
36	33X 152	24X 68	15X 33.9	24X 68	26X .5000
38	36X 170	24X 68	15X 33.9	24X 68	26X .5000
40	36X 182	24X 76	15X 33.9	27X 84	29X .5000
42	36X 182	24X 84	15X 33.9	27X 84	29X .5000
44	36X 194	27X 84	15X 33.9	27X 84	29X .5000
46	36X 210	27X 84	18X 42.7	30X 99	32X .5000
48	36X 210	27X 84	18X 51.9	30X 99	32X .5000
50	36X 232	27X 94	18X 42.7	30X 99	32X .5000
52	36X 232	30X 99	18X 42.7	30X 99	32X .5000
54	36X 256	30X 99	18X 51.9	33X 118	35X .6250
56	36X 256	30X 99	18X 51.9	33X 118	35X .6250
58	36X 260	30X 124	18X 42.7	33X 118	35X .6250
60	36X 260	30X 116	18X 51.9	33X 118	35X .6250

Span Thru (ft)	W	Ww/C		Ww/PL	
		W	C	W	PL
25 TON RATED LOAD					
20	16X 77	18X 60	12X 20.7	16X 67	18X .3125
22	16X 77	21X 62	12X 20.7	21X 62	23X .3750
24	16X 89	21X 62	12X 20.7	21X 62	23X .3750
26	16X 100	21X 68	12X 20.7	18X 76	20X .3125
28	33X 130	24X 68	12X 20.7	24X 68	26X .5000
30	33X 141	24X 76	12X 20.7	24X 68	26X .5000
32	33X 152	21X 83	12X 20.7	24X 68	26X .5000
34	33X 152	24X 76	15X 33.9	21X 101	23X .3750
36	36X 170	24X 94	12X 20.7	27X 84	29X .5000
38	36X 182	24X 84	15X 33.9	27X 84	29X .5000
40	36X 194	27X 84	15X 33.9	27X 84	29X .5000
42	36X 210	27X 84	18X 42.7	30X 99	32X .5000
44	36X 210	27X 94	18X 42.7	30X 99	32X .5000
46	36X 232	30X 99	18X 42.7	30X 99	32X .5000
48	36X 232	30X 99	18X 42.7	30X 99	32X .5000
50	36X 256	30X 99	18X 51.9	33X 118	35X .6250
52	36X 256	30X 116	18X 42.7	33X 118	35X .6250
54	36X 260	30X 124	18X 42.7	33X 118	35X .6250
56	36X 260	33X 118	18X 51.9	33X 118	35X .6250
58	36X 260	33X 130	18X 58.0	33X 118	35X .6250
60	36X 260	33X 130	18X 58.0	36X 150	38X .6250

BEAM SIZE SELECTION FOR VARIOUS SPANS

ENGLISH MEASURE (TONS)

LOADMAX TROLLEYS

1. Section designation is in accordance with AISC.
2. Beam sizes listed are American standard (S) beams, wide flange (W) and channel (C) sections and plate (PL).
3. Use ASTM A 36 grade steel, first quality, free of rust and excessive mill scale.
4. The bridge is designed in accordance with CMAA Specification 70, revised 1994 and is based on the following assumptions:

Rated Load	Trolley Load	Gage
10 Ton	6130#	84"
15	6820	84
20	6820	84
25	7150	84

Tons are short tons.

DLFB, DLFT, HLF and IFD are assumed to be 1.1, 1.1, .15 and .1 respectively.

Bridge speed is assumed to be 150 FPM.

Bridge class of service is assumed to be C.

Assumed additional dead load is 10 #/ for both front and back girders.

The bridge is assumed to be an indoor bridge.

5. If any of the above assumptions are exceeded contact the factory for girder selection.

6. No additional loading such as footwalks, platforms, cabs, machinery, etc., is allowed.

Span Thru (ft)	W	Ww/C		Ww/PL	
		W	C	W	PL
15 TON RATED LOAD					
20	14X 61	18X 50	10X 15.3	18X 50	20X .3125
22	14X 61	18X 50	10X 15.3	18X 50	20X .3125
24	16X 67	18X 50	10X 15.3	18X 50	20X .3125
26	16X 77	18X 50	10X 15.3	16X 67	18X .3125
28	16X 89	24X 62	10X 15.3	16X 67	18X .3125
30	16X 89	18X 60	12X 20.7	21X 62	23X .3750
32	16X 100	21X 62	12X 20.7	21X 62	23X .3750
34	30X 124	21X 62	12X 20.7	21X 62	23X .3750
36	30 X132	21X 68	12X 20.7	24X 68	26X .5000
38	33X 141	21X 73	12X 20.7	24X 68	26X .5000
40	33X 152	24X 62	15X 33.9	24X 68	26X .5000
42	36X 170	24X 68	15X 33.9	24X 68	26X .5000
44	36X 170	24X 68	15X 33.9	27X 84	29X .5000
46	36X 182	24X 76	15X 33.9	27X 84	29X .5000
48	36X 194	24X 84	15X 33.9	27X 84	29X .5000
50	36X 210	27X 84	15X 33.9	27X 84	29X .5000
52	36X 210	27X 84	18X 42.7	30X 99	32X .5000
54	36X 232	27X 84	18X 42.7	30X 99	32X .5000
56	36X 232	27X 94	18X 42.7	30X 99	32X .5000
58	36X 256	30X 99	18X 42.7	30X 99	32X .5000
60	36X 256	30X 99	18X 51.9	30X 99	32X .5000

Span Thru (ft)	W	Ww/C		Ww/PL	
		W	C	W	PL
10 TON RATED LOAD					
20	14X 53	16X 36	10X 15.3	16X 36	18X .3125
22	14X 61	16X 36	10X 15.3	16X 36	18X .3125
24	14X 61	14X 43	12X 20.7	18X 50	20X .3125
26	14X 61	18X 50	10X 15.3	18X 50	20X .3125
28	16X 77	18X 50	10X 15.3	18X 50	20X .3125
30	16X 77	18X 50	10X 15.3	18X 50	20X .3125
32	16X 89	18X 50	10X 15.3	16X 67	18X .3125
34	16X 89	18X 50	12X 20.7	16X 67	18X .3125
36	16X 100	18X 60	12X 20.7	21X 62	23X .3750
38	16X 100	21X 62	12X 20.7	21X 62	23X .3750
40	30X 132	21X 68	12X 20.7	21X 62	23X .3750
42	33X 141	21X 73	12X 20.7	21X 62	23X .3750
44	33X 152	21X 62	15X 33.9	24X 68	26X .5000
46	36X 170	24X 62	15X 33.9	24X 68	26X .5000
48	36X 170	24X 62	15X 33.9	24X 68	26X .5000
50	36X 182	24X 68	15X 33.9	24X 68	26X .5000
52	36X 194	24X 76	15X 33.9	27X 84	29X .5000
54	36X 210	24X 76	15X 33.9	27X 84	29X .5000
56	36X 210	24X 84	15X 33.9	27X 84	29X .5000
58	36X 232	24X 84	18X 42.7	27X 84	29X .5000
60	36X 232	27X 84	18X 42.7	27X 84	29X .5000

Span Thru (ft)	W	Ww/C		Ww/PL	
		W	C	W	PL
20 TON RATED LOAD					
20	16X 77	16X 50	12X 20.7	18X 50	20X .3125
22	16X 77	16X 57	12X 20.7	16X 67	18X .3125
24	16X 77	18X 60	12X 20.7	16X 67	18X .3125
26	16X 89	18X 60	12X 20.7	21X 62	23X .3750
28	16X 100	21X 62	12X 20.7	21X 62	23X .3750
30	24X 104	21X 62	12X 20.7	24X 68	26X .5000
32	30X 132	21X 68	12X 20.7	24X 68	26X .5000
34	33X 141	21X 73	12X 20.7	24X 68	26X .5000
36	33X 152	24X 68	15X 33.9	24X 68	26X .5000
38	36X 170	24X 68	15X 33.9	24X 68	26X .5000
40	36X 170	24X 76	15X 33.9	27X 84	29X .5000
42	36X 182	24X 84	15X 33.9	27X 84	29X .5000
44	36X 194	27X 84	15X 33.9	27X 84	29X .5000
46	36X 210	27X 84	18X 42.7	27X 84	29X .5000
48	36X 210	27X 84	18X 42.7	30X 99	32X .5000
50	36X 232	27X 94	18X 42.7	30X 99	32X .5000
52	36X 232	30X 99	18X 42.7	30X 99	32X .5000
54	36X 256	30X 99	18X 51.9	33X 118	35X .6250
56	36X 256	30X 99	18X 51.9	33X 118	35X .6250
58	36X 256	30X 124	18X 42.7	33X 118	35X .6250
60	36X 260	30X 116	18X 51.9	33X 118	35X .6250

ENGLISH MEASURE (TONS) LOADMAX TROLLEYS

Span Thru (ft)	W	Ww/C		Ww/PL	
		W	C	W	PL
25 TON RATED LOAD					
20	21X 83	18X 60	12X 20.7	16X 67	18X .3125
22	16X 89	18X 60	12X 20.7	16X 67	18X .3125
24	16X 89	18X 65	12X 20.7	21X 62	23X .3750
26	16X 100	21X 68	12X 20.7	18X 76	20X .3125
28	24X 104	21X 68	12X 20.7	24X 68	26X .5000
30	30X 132	21X 73	12X 20.7	24X 68	26X .5000
32	36X 150	24X 76	12X 20.7	24X 68	26X .5000
34	33X 152	24X 84	12X 20.7	21X 101	23X .3750
36	36X 170	24X 76	15X 33.9	27X 84	29X .5000
38	36X 182	24X 84	15X 33.9	27X 84	29X .5000
40	36X 194	27X 84	15X 33.9	27X 84	29X .5000
42	36X 194	27X 84	15X 33.9	30X 99	32X .5000
44	36X 210	27X 94	15X 33.9	30X 99	32X .5000
46	36X 232	27X 94	18X 42.7	30X 99	32X .5000
48	36X 232	30X 99	18X 42.7	30X 99	32X .5000
50	36X 232	30X 99	18X 51.9	33X 118	35X .6250
52	36X 256	30X 99	18X 51.9	33X 118	35X .6250
54	36X 256	30X 124	18X 42.7	33X 118	35X .6250
56	36X 260	33X 118	18X 51.9	33X 118	35X .6250
58	36X 260	30X 124	18X 58.0	33X 118	35X .6250
60	36X 260	33X 130	18X 58.0	36X 150	38X .6250

BEAM SIZE SELECTION FOR VARIOUS SPANS

METRIC MEASURE (TONNES)

SERIES 700 TROLLEY KIT

1. Section designation is in accordance with AISC.
2. Beam sizes listed are American standard (S) beams, wide flange (W) and channel (C) sections and plate (PL).
3. Use ASTM A 36 grade steel, first quality, free of rust and excessive mill scale.
4. The bridge is designed in accordance with CMAA Specification 70, revised 1994 and is based on the following assumptions:

Rated Load	Trolley Load	Reeved	Gage
5 Tonne	1127kg	Single	78"
7-1/2	1127	Single	78
10	1989	Single	78
15	2025	Single	78
20	2343	Single	78
25	2343	Single	78

Tonnes are metric.

DLFB, DLFT, HLF and IFD are assumed to be 1.1, 1.1, .15 and .1 respectively.

Bridge speed is assumed to be 150 FPM.

Bridge class of service is assumed to be C.

Assumed additional dead load is 5 kg/' for both front and back girders.

The bridge is assumed to be an indoor bridge.

5. If any of the above assumptions are exceeded contact the factory for girder selection.

6. No additional loading such as footwalks, platforms, cabs, machinery, etc., is allowed.

Span Thru (ft)	W	Ww/C		Ww/PL	
		W	C	W	PL
7-1/2 TONNE RATED LOAD					
20	14X 48	16X 36	10X 15.3	16X 36	18X .3125
22	14X 53	16X 36	10X 15.3	16X 36	18X .3125
24	14X 61	16X 36	10X 15.3	18X 50	20X .3125
26	16X 67	18X 50	10X 15.3	18X 50	20X .3125
28	16X 67	18X 50	10X 15.3	18X 50	20X .3125
30	16X 77	18X 50	10X 15.3	18X 50	20X .3125
32	16X 89	18X 50	12X 20.7	21X 62	23X .3750
34	16X 89	18X 60	12X 20.7	21X 62	23X .3750
36	16X 100	21X 62	12X 20.7	21X 62	23X .3750
38	24X 104	21X 62	12X 20.7	21X 62	23X .3750
40	30X 132	21X 62	12X 20.7	24X 68	26X .5000
42	33X 141	21X 68	12X 20.7	24X 68	26X .5000
44	33X 152	24X 62	15X 33.9	24X 68	26X .5000
46	36X 160	24X 62	15X 33.9	24X 68	26X .5000
48	36X 170	24X 68	15X 33.9	21X 101	23X .3750
50	36X 182	24X 76	15X 33.9	27X 84	29X .5000
52	36X 194	24X 84	15X 33.9	27X 84	29X .5000
54	36X 194	24X 84	15X 33.9	27X 84	29X .5000
56	36X 210	27X 84	18X 42.7	27X 84	29X .5000
58	36X 232	27X 84	18X 42.7	27X 84	29X .5000
60	36X 232	27X 84	18X 42.7	30X 99	32X .5000

Span Thru (ft)	W	Ww/C		Ww/PL	
		W	C	W	PL
5 TONNE RATED LOAD					
20	14X 43	12X 26	9X 13.4	14X 30	16X .2500
22	14X 48	14X 30	9X 13.4	14X 30	16X .2500
24	14X 53	14X 30	9X 13.4	16X 36	18X .3125
26	14X 53	16X 36	10X 15.3	16X 36	18X .3125
28	14X 61	16X 36	10X 15.3	16X 36	18X .3125
30	16X 67	16X 36	10X 15.3	18X 50	20X .3125
32	16X 67	18X 50	10X 15.3	18X 50	20X .3125
34	16X 77	18X 50	10X 15.3	18X 50	20X .3125
36	16X 77	18X 50	10X 15.3	18X 50	20X .3125
38	16X 89	18X 50	10X 15.3	16X 67	18X .3125
40	16X 89	18X 60	12X 20.7	21X 62	23X .3750
42	16X 100	21X 62	12X 20.7	21X 62	23X .3750
44	33X 130	21X 62	12X 20.7	21X 62	23X .3750
46	30X 132	21X 62	12X 20.7	21X 62	23X .3750
48	36X 150	21X 68	12X 20.7	24X 68	26X .5000
50	33X 152	21X 73	12X 20.7	24X 68	26X .5000
52	36X 170	24X 62	15X 33.9	24X 68	26X .5000
54	36X 170	24X 62	15X 33.9	24X 68	26X .5000
56	36X 182	24X 68	15X 33.9	24X 68	26X .5000
58	36X 194	24X 68	15X 33.9	21X 101	23X .3750
60	36X 210	24X 76	15X 33.9	27X 84	29X .5000

Span Thru (ft)	W	Ww/C		Ww/PL	
		W	C	W	PL
10 TONNE RATED LOAD					
20	14X 61	18X 50	10X 15.3	18X 50	20X .3125
22	14X 61	18X 50	10X 15.3	18X 50	20X .3125
24	16X 67	18X 50	10X 15.3	18X 50	20X .3125
26	16X 77	18X 50	10X 15.3	16X 67	18X .3125
28	16X 89	18X 60	12X 20.7	16X 67	18X .3125
30	16X 89	18X 60	12X 20.7	21X 62	23X .3750
32	16X 100	21X 62	12X 20.7	21X 62	23X .3750
34	30X 132	21X 62	12X 20.7	21X 62	23X .3750
36	33X 141	21X 68	12X 20.7	24X 68	26X .5000
38	36X 150	21X 73	12X 20.7	24X 68	26X .5000
40	33X 152	24X 62	15X 33.9	24X 68	26X .5000
42	36X 170	24X 68	15X 33.9	24X 68	26X .5000
44	36X 182	24X 76	15X 33.9	27X 84	29X .5000
46	36X 194	24X 84	15X 33.9	27X 84	29X .5000
48	36X 194	27X 84	15X 33.9	27X 84	29X .5000
50	36X 210	27X 84	18X 42.7	27X 84	29X .5000
52	36X 232	27X 84	18X 42.7	30X 99	32X .5000
54	36X 232	27X 84	18X 51.9	30X 99	32X .5000
56	36X 232	27X 94	18X 42.7	30X 99	32X .5000
58	36X 256	30X 99	18X 51.9	30X 99	32X .5000
60	36X 256	30X 99	18X 51.9	33X 118	35X .6250

METRIC MEASURE (TONNES) SERIES 700 TROLLEY KIT

Span Thru (ft)	W	Ww/C		Ww/PL	
		W	C	W	PL
15 TONNE RATED LOAD					
20	16X 67	24X 62	10X 15.3	16X 67	18X .3125
22	16X 77	24X 62	10X 15.3	16X 67	18X .3125
24	16X 89	21X 62	12X 20.7	21X 62	23X .3750
26	16X 100	21X 62	12X 20.7	21X 62	23X .3750
28	24X 104	21X 68	12X 20.7	24X 68	26X .5000
30	30X 132	24X 68	12X 20.7	24X 68	26X .5000
32	36X 150	24X 76	12X 20.7	24X 68	26X .5000
34	33X 152	24X 84	12X 20.7	21X 101	23X .3750
36	36X 170	24X 76	15X 33.9	21X 101	23X .3750
38	36X 182	24X 84	15X 33.9	27X 84	29X .5000
40	36X 194	27X 84	15X 33.9	27X 84	29X .5000
42	36X 194	27X 84	15X 33.9	27X 84	29X .5000
44	36X 210	27X 84	18X 42.7	30X 99	32X .5000
46	36X 232	27X 94	18X 42.7	30X 99	32X .5000
48	36X 232	30X 99	18X 42.7	30X 99	32X .5000
50	36X 232	30X 99	18X 51.9	30X 99	32X .5000
52	36X 256	30X 99	18X 51.9	33X 118	35X .6250
54	36X 256	30X 124	18X 42.7	33X 118	35X .6250
56	36X 260	30X 116	18X 51.9	33X 118	35X .6250
58	36X 260	33X 124	18X 58.0	33X 118	35X .6250
60	36X 260	33X 130	18X 58.0	33X 118	35X .6250

Span Thru (ft)	W	Ww/C		Ww/PL	
		W	C	W	PL
25 TONNE RATED LOAD					
20	16X 89	21X 73	12X 20.7	21X 62	23X .3750
22	16X 100	21X 73	12X 20.7	24X 68	26X .5000
24	24X 104	24X 76	12X 20.7	24X 68	26X .5000
26	30X 132	24X 76	12X 20.7	21X 101	23X .3750
28	36X 150	24X 84	12X 20.7	21X 101	23X .3750
30	33X 152	24X 94	12X 20.7	21X 101	23X .3750
32	36X 170	27X 84	15X 33.9	27X 84	29X .5000
34	36X 182	27X 84	18X 42.7	24X 104	26X .5000
36	36X 194	27X 94	15X 33.9	24X 104	26X .5000
38	36X 210	30X 99	15X 33.9	30X 99	32X .5000
40	36X 232	30X 99	18X 42.7	33X 118	35X .6250
42	36X 232	27X 114	15X 33.9	33X 118	35X .6250
44	36X 232	30X 116	18X 42.7	33X 118	35X .6250
46	36X 256	30X 116	18X 42.7	33X 118	35X .6250
48	36X 256	30X 124	18X 42.7	33X 118	35X .6250
50	36X 260	33X 118	18X 51.9	33X 118	35X .6250
52	36X 260	33X 130	18X 58.0	36X 150	38X .6250
54	36X 260	33X 130	18X 58.0	36X 150	38X .6250
56	36X 280	33X 130	18X 58.0	36X 150	38X .6250
58	36X 280	33X 141	18X 58.0	36X 150	38X .6250
60	36X 300	33X 152	18X 58.0	36X 150	38X .6250

Span Thru (ft)	W	Ww/C		Ww/PL	
		W	C	W	PL
20 TONNE RATED LOAD					
20	16X 77	18X 60	12X 20.7	16X 67	18X .3125
22	16X 77	21X 62	12X 20.7	21X 62	23X .3750
24	16X 89	21X 62	12X 20.7	21X 62	23X .3750
26	24X 104	21X 68	12X 20.7	24X 68	26X .5000
28	30X 132	24X 68	12X 20.7	24X 68	26X .5000
30	33X 141	24X 76	12X 20.7	24X 68	26X .5000
32	33X 152	24X 84	12X 20.7	21X 101	23X .3750
34	36X 170	24X 76	15X 33.9	21X 101	23X .3750
36	36X 182	24X 84	15X 33.9	27X 84	29X .5000
38	36X 182	27X 84	15X 33.9	27X 84	29X .5000
40	36X 194	27X 84	18X 42.7	30X 99	32X .5000
42	36X 210	27X 94	15X 33.9	30X 99	32X .5000
44	36X 232	27X 94	18X 42.7	30X 99	32X .5000
46	36X 232	30X 99	18X 42.7	30X 99	32X .5000
48	36X 232	30X 99	18X 51.9	33X 118	35X .6250
50	36X 256	30X 99	18X 51.9	33X 118	35X .6250
52	36X 256	30X 124	18X 42.7	33X 118	35X .6250
54	36X 260	30X 116	18X 51.9	33X 118	35X .6250
56	36X 260	30X 124	18X 58.0	33X 118	35X .6250
58	36X 260	33X 130	18X 58.0	36X 150	38X .6250
60	36X 280	33X 130	18X 58.0	36X 150	38X .6250

BEAM SIZE SELECTION FOR VARIOUS SPANS

METRIC MEASURE (TONNES)

DMR-3 TROLLEYS

1. Section designation is in accordance with AISC.
2. Beam sizes listed are American standard (S) beams, wide flange (W) and channel (C) sections and plate (PL).
3. Use ASTM A 36 grade steel, first quality, free of rust and excessive mill scale.
4. The bridge is designed in accordance with CMAA Specification 70, revised 1994 and is based on the following assumptions:

Rated Load	Trolley Load	Gage
7-1/2 Tonne	2268kg	72"
10	2268	72
15	2409	84
20	2454	84
25	2590	84

Tonnes are metric.

DLFB, DLFT, HLF and IFD are assumed to be 1.1, 1.1, .15 and .1 respectively.

Bridge speed is assumed to be 150 FPM.

Bridge class of service is assumed to be C.

Assumed additional dead load is 5 kg/' for both front and back girders.

The bridge is assumed to be an indoor bridge.

5. If any of the above assumptions are exceeded contact the factory for girder selection.

6. No additional loading such as footwalks, platforms, cabs, machinery, etc., is allowed.

Span Thru (ft)	W	Ww/C		Ww/PL	
		W	C	W	PL
10 TONNE RATED LOAD					
20	14X 48	16X 36	10X 15.3	16X 36	18X .3125
22	14X 53	16X 36	10X 15.3	16X 36	18X .3125
24	14X 61	16X 36	12X 20.7	18X 50	20X .3125
26	16X 67	18X 50	10X 15.3	18X 50	20X .3125
28	16X 77	18X 50	10X 15.3	18X 50	20X .3125
30	16X 77	18X 50	10X 15.3	18X 50	20X .3125
32	16X 89	18X 50	12X 20.7	21X 62	23X .3750
34	16X 100	18X 60	12X 20.7	21X 62	23X .3750
36	24X 104	21X 62	12X 20.7	21X 62	23X .3750
38	24X 104	21X 62	12X 20.7	21X 62	23X .3750
40	30X 132	21X 68	12X 20.7	24X 68	26X .5000
42	33X 141	21X 73	12X 20.7	24X 68	26X .5000
44	33X 152	24X 62	15X 33.9	24X 68	26X .5000
46	36X 170	24X 68	15X 33.9	24X 68	26X .5000
48	36X 170	24X 68	15X 33.9	21X 101	23X .3750
50	36X 182	24X 76	15X 33.9	27X 84	29X .5000
52	36X 194	24X 84	15X 33.9	27X 84	29X .5000
54	36X 194	27X 84	15X 33.9	27X 84	29X .5000
56	36X 210	27X 84	18X 42.7	27X 84	29X .5000
58	36X 232	27X 84	18X 42.7	30X 99	32X .5000
60	36X 232	27X 84	18X 51.9	30X 99	32X .5000

Span Thru (ft)	W	Ww/C		Ww/PL	
		W	C	W	PL
7-1/2 TONNE RATED LOAD					
20	14X 43	14X 30	9X 13.4	14X 30	16X .2500
22	14X 48	14X 30	9X 13.4	16X 36	18X .3125
24	14X 53	16X 36	10X 15.3	16X 36	18X .3125
26	14X 61	16X 36	10X 15.3	16X 36	18X .3125
28	16X 67	16X 36	12X 20.7	18X 50	20X .3125
30	16X 67	18X 50	10X 15.3	18X 50	20X .3125
32	16X 77	18X 50	10X 15.3	18X 50	20X .3125
34	16X 77	18X 50	10X 15.3	18X 50	20X .3125
36	16X 89	18X 60	12X 20.7	21X 62	23X .3750
38	16X 100	18X 60	12X 20.7	21X 62	23X .3750
40	16X 100	21X 62	12X 20.7	21X 62	23X .3750
42	33X 130	21X 62	12X 20.7	21X 62	23X .3750
44	30X 132	21X 62	12X 20.7	24X 68	26X .5000
46	33X 141	21X 68	12X 20.7	24X 68	26X .5000
48	33X 152	24X 62	15X 33.9	24X 68	26X .5000
50	36X 170	24X 62	15X 33.9	24X 68	26X .5000
52	36X 170	24X 68	15X 33.9	24X 68	26X .5000
54	36X 182	24X 68	15X 33.9	21X 101	23X .3750
56	36X 194	24X 76	15X 33.9	27X 84	29X .5000
58	36X 194	24X 84	15X 33.9	27X 84	29X .5000
60	36X 210	27X 84	15X 33.9	27X 84	29X .5000

Span Thru (ft)	W	Ww/C		Ww/PL	
		W	C	W	PL
15 TONNE RATED LOAD					
20	14X 61	18X 50	10X 15.3	18X 50	20X .3125
22	16X 67	18X 50	10X 15.3	18X 50	20X .3125
24	16X 77	18X 50	10X 15.3	18X 50	20X .3125
26	16X 77	18X 50	12X 20.7	16X 67	18X .3125
28	16X 89	18X 60	12X 20.7	21X 62	23X .3750
30	16X 100	21X 62	12X 20.7	21X 62	23X .3750
32	24X 104	21X 62	12X 20.7	21X 62	23X .3750
34	30X 132	21X 62	12X 20.7	24X 68	26X .5000
36	33X 141	21X 73	12X 20.7	24X 68	26X .5000
38	33X 152	24X 62	15X 33.9	24X 68	26X .5000
40	36X 160	24X 68	15X 33.9	24X 68	26X .5000
42	36X 170	24X 76	15X 33.9	27X 84	29X .5000
44	36X 182	24X 84	15X 33.9	27X 84	29X .5000
46	36X 194	27X 84	15X 33.9	27X 84	29X .5000
48	36X 210	27X 84	15X 33.9	27X 84	29X .5000
50	36X 210	27X 84	18X 42.7	30X 99	32X .5000
52	36X 232	27X 84	18X 51.9	30X 99	32X .5000
54	36X 232	30X 99	18X 42.7	30X 99	32X .5000
56	36X 232	30X 99	18X 42.7	30X 99	32X .5000
58	36X 256	30X 99	18X 51.9	33X 118	35X .6250
60	36X 256	30X 99	18X 51.9	33X 118	35X .6250

METRIC MEASURE (TONNES) DMR-3 TROLLEYS

Span Thru (ft)	W	Ww/C		Ww/PL	
		W	C	W	PL
20 TONNE RATED LOAD					
20	16X 77	18X 50	12X 20.7	16X 67	18X .3125
22	16X 77	18X 60	12X 20.7	16X 67	18X .3125
24	16X 89	18X 60	12X 20.7	16X 67	18X .3125
26	16X 89	21X 62	12X 20.7	21X 62	23X .3750
28	24X 104	21X 62	12X 20.7	18X 76	20X .3125
30	30X 132	21X 68	12X 20.7	24X 68	26X .5000
32	33X 141	21X 73	12X 20.7	24X 68	26X .5000
34	33X 152	24X 68	15X 33.9	24X 68	26X .5000
36	36X 160	24X 76	15X 33.9	21X 101	23X .3750
38	36X 170	24X 76	15X 33.9	27X 84	29X .5000
40	36X 182	24X 84	15X 33.9	27X 84	29X .5000
42	36X 194	27X 84	15X 33.9	27X 84	29X .5000
44	36X 210	27X 84	18X 42.7	27X 84	29X .5000
46	36X 210	27X 94	15X 33.9	30X 99	32X .5000
48	36X 232	27X 94	18X 42.7	30X 99	32X .5000
50	36X 232	30X 99	18X 42.7	30X 99	32X .5000
52	36X 256	30X 99	18X 51.9	33X 118	35X .6250
54	36X 256	30X 99	18X 51.9	33X 118	35X .6250
56	36X 256	30X 124	18X 42.7	33X 118	35X .6250
58	36X 260	30X 116	18X 51.9	33X 118	35X .6250
60	36X 260	30X 124	18X 58.0	33X 118	35X .6250

Span Thru (ft)	W	Ww/C		Ww/PL	
		W	C	W	PL
25 TONNE RATED LOAD					
20	16X 89	18X 60	12X 20.7	16X 67	18X .3125
22	16X 89	21X 68	12X 20.7	21X 62	23X .3750
24	16X 100	21X 68	12X 20.7	18X 76	20X .3125
26	24X 104	21X 73	12X 20.7	24X 68	26X .5000
28	30X 132	24X 76	12X 20.7	24X 68	26X .5000
30	33X 141	24X 76	12X 20.7	21X 101	23X .3750
32	33X 152	24X 84	12X 20.7	21X 101	23X .3750
34	36X 170	24X 94	12X 20.7	27X 84	29X .5000
36	36X 182	27X 84	15X 33.9	27X 84	29X .5000
38	36X 194	27X 84	15X 33.9	27X 84	29X .5000
40	36X 210	27X 94	15X 33.9	30X 99	32X .5000
42	36X 210	27X 94	15X 33.9	30X 99	32X .5000
44	36X 232	30X 99	18X 42.7	30X 99	32X .5000
46	36X 232	30X 99	18X 42.7	33X 118	35X .6250
48	36X 256	30X 99	18X 51.9	33X 118	35X .6250
50	36X 256	30X 116	18X 42.7	33X 118	35X .6250
52	36X 260	30X 124	18X 42.7	33X 118	35X .6250
54	36X 260	33X 118	18X 51.9	33X 118	35X .6250
56	36X 260	33X 130	18X 58.0	33X 118	35X .6250
58	36X 260	33X 130	18X 58.0	36X 150	38X .6250
60	36X 280	33X 130	18X 58.0	36X 150	38X .6250

BEAM SIZE SELECTION FOR VARIOUS SPANS

METRIC MEASURE (TONNES)

LOADMAX TROLLEYS

1. Section designation is in accordance with AISC.
2. Beam sizes listed are American standard (S) beams, wide flange (W) and channel (C) sections and plate (PL).
3. Use ASTM A 36 grade steel, first quality, free of rust and excessive mill scale.
4. The bridge is designed in accordance with CMAA Specification 70, revised 1994 and is based on the following assumptions:

Rated Load	Trolley Load	Gage
10 Tonne	2781kg	84"
15	3094	84
20	3094	84
25	3243	84

Tonnes are metric.

DLFB, DLFT, HLF and IFD are assumed to be 1.1, 1.1, .15 and .1 respectively.

Bridge speed is assumed to be 150 FPM.

Bridge class of service is assumed to be C.

Assumed additional dead load is 5 kg/' for both front and back girders.

The bridge is assumed to be an indoor bridge.

5. If any of the above assumptions are exceeded contact the factory for girder selection.

6. No additional loading such as footwalks, platforms, cabs, machinery, etc., is allowed.

Span Thru (ft)	W	Ww/C		Ww/PL	
		W	C	W	PL
15 TONNE RATED LOAD					
20	16X 67	18X 50	10X 15.3	18X 50	20X .3125
22	16X 67	18X 50	10X 15.3	18X 50	20X .3125
24	16X 77	18X 50	10X 15.3	18X 50	20X .3125
26	16X 77	24X 62	10X 15.3	16X 67	18X .3125
28	16X 89	18X 60	12X 20.7	21X 62	23X .3750
30	16X 100	18X 60	12X 20.7	21X 62	23X .3750
32	24X 104	21X 62	12X 20.7	21X 62	23X .3750
34	30X 132	21X 62	12X 20.7	24X 68	26X .5000
36	33X 141	21X 68	12X 20.7	24X 68	26X .5000
38	33X 152	24X 62	15X 33.9	24X 68	26X .5000
40	36X 160	24X 68	15X 33.9	24X 68	26X .5000
42	36X 170	24X 68	15X 33.9	21X 101	23X .3750
44	36X 182	24X 76	15X 33.9	27X 84	29X .5000
46	36X 194	24X 84	15X 33.9	27X 84	29X .5000
48	36X 210	27X 84	15X 33.9	27X 84	29X .5000
50	36X 210	27X 84	18X 42.7	30X 99	32X .5000
52	36X 232	27X 84	18X 42.7	30X 99	32X .5000
54	36X 232	27X 94	18X 42.7	30X 99	32X .5000
56	36X 232	30X 99	18X 42.7	30X 99	32X .5000
58	36X 256	30X 99	18X 51.9	30X 99	32X .5000
60	36X 256	30X 99	18X 51.9	33X 118	35X .6250

Span Thru (ft)	W	Ww/C		Ww/PL	
		W	C	W	PL
10 TONNE RATED LOAD					
20	14X 53	16X 36	12X 20.7	16X 36	18X .3125
22	14X 61	14X 43	12X 20.7	12X 53	14X .3125
24	14X 61	18X 50	10X 15.3	18X 50	20X .3125
26	16X 67	18X 50	10X 15.3	18X 50	20X .3125
28	16X 77	18X 50	10X 15.3	18X 50	20X .3125
30	16X 77	18X 50	10X 15.3	16X 67	18X .3125
32	16X 89	18X 50	12X 20.7	16X 67	18X .3125
34	16X 89	18X 60	12X 20.7	21X 62	23X .3750
36	16X 100	18X 60	12X 20.7	21X 62	23X .3750
38	30X 132	21X 62	12X 20.7	21X 62	23X .3750
40	33X 141	21X 68	12X 20.7	21X 62	23X .3750
42	33X 152	21X 62	15X 33.9	24X 68	26X .5000
44	33X 152	24X 62	15X 33.9	24X 68	26X .5000
46	36X 170	24X 62	15X 33.9	24X 68	26X .5000
48	36X 182	24X 68	15X 33.9	24X 68	26X .5000
50	36X 194	24X 68	15X 33.9	27X 84	29X .5000
52	36X 194	24X 76	15X 33.9	27X 84	29X .5000
54	36X 210	24X 84	15X 33.9	27X 84	29X .5000
56	36X 232	27X 84	18X 42.7	27X 84	29X .5000
58	36X 232	27X 84	18X 42.7	27X 84	29X .5000
60	36X 232	27X 84	18X 42.7	30X 99	32X .5000

Span Thru (ft)	W	Ww/C		Ww/PL	
		W	C	W	PL
20 TONNE RATED LOAD					
20	16X 77	16X 57	12X 20.7	16X 67	18X .3125
22	16X 77	18X 60	12X 20.7	16X 67	18X .3125
24	16X 77	18X 60	12X 20.7	16X 67	18X .3125
26	16X 89	21X 62	12X 20.7	21X 62	23X .3750
28	24X 104	21X 62	12X 20.7	18X 76	20X .3125
30	33X 130	21X 68	12X 20.7	24X 68	26X .5000
32	33X 141	21X 73	12X 20.7	24X 68	26X .5000
34	33X 152	24X 76	12X 20.7	24X 68	26X .5000
36	33X 152	24X 84	12X 20.7	21X 101	23X .3750
38	36X 170	24X 76	15X 33.9	27X 84	29X .5000
40	36X 182	24X 84	15X 33.9	27X 84	29X .5000
42	36X 194	27X 84	15X 33.9	27X 84	29X .5000
44	36X 210	27X 84	15X 33.9	27X 84	29X .5000
46	36X 210	27X 84	18X 42.7	30X 99	32X .5000
48	36X 232	27X 94	18X 42.7	30X 99	32X .5000
50	36X 232	30X 99	18X 42.7	30X 99	32X .5000
52	36X 232	30X 99	18X 51.9	33X 118	35X .6250
54	36X 256	30X 99	18X 51.9	33X 118	35X .6250
56	36X 256	30X 124	18X 42.7	33X 118	35X .6250
58	36X 260	30X 116	18X 51.9	33X 118	35X .6250
60	36X 260	33X 118	18X 51.9	33X 118	35X .6250

METRIC MEASURE (TONNES) LOADMAX TROLLEYS

Span Thru (ft)	W	Ww/C		Ww/PL	
		W	C	W	PL
25 TONNE RATED LOAD					
20	16X 89	18X 65	12X 20.7	16X 67	18X .3125
22	16X 89	18X 65	12X 20.7	21X 62	23X .3750
24	16X 100	18X 71	12X 20.7	18X 76	20X .3125
26	24X 104	21X 73	12X 20.7	24X 68	26X .5000
28	30X 132	24X 76	12X 20.7	24X 68	26X .5000
30	33X 141	24X 76	12X 20.7	24X 68	26X .5000
32	33X 152	24X 84	12X 20.7	21X 101	23X .3750
34	36X 170	24X 94	12X 20.7	27X 84	29X .5000
36	36X 182	24X 84	15X 33.9	27X 84	29X .5000
38	36X 182	27X 84	15X 33.9	27X 84	29X .5000
40	36X 194	27X 84	18X 42.7	30X 99	32X .5000
42	36X 210	27X 94	15X 33.9	30X 99	32X .5000
44	36X 232	30X 99	18X 42.7	30X 99	32X .5000
46	36X 232	30X 99	18X 42.7	30X 99	32X .5000
48	36X 232	30X 99	18X 51.9	33X 118	35X .6250
50	36X 256	30X 116	18X 42.7	33X 118	35X .6250
52	36X 256	30X 124	18X 42.7	33X 118	35X .6250
54	36X 260	33X 118	18X 51.9	33X 118	35X .6250
56	36X 260	30X 124	18X 58.0	33X 118	35X .6250
58	36X 260	33X 130	18X 58.0	36X 150	38X .6250
60	36X 280	33X 130	18X 58.0	36X 150	38X .6250

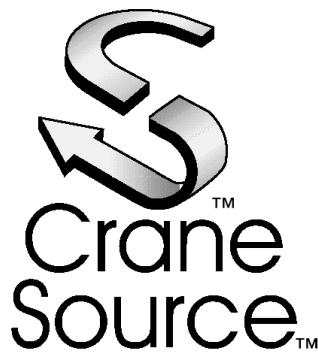

414 West Broadway Ave.
P.O. Box 769
Muskegon, MI 49443-0769
(800) 742-9269 Phone
(800) 742-9270 Fax

WARRANTY

WARRANTY AND LIMITATION OF REMEDY AND LIABILITY

A. Seller warrants that its products and parts, when shipped, and its work (including installation, construction and start-up), when performed, will meet applicable specifications, will be of good quality and will be free from defects in material and workmanship. All claims for defective products or parts under this warranty must be made in writing immediately upon discovery and, in any event, within one (1) year from shipment of the applicable item unless Seller specifically assumes installation, construction or start-up responsibility. All claims for defective products or parts when Seller specifically assumes installation, construction or start-up responsibility, and all claims for defective work must be made in writing immediately upon discovery and, in any event, within one (1) year from completion of the applicable work by Seller, provided, however, all claims for defective products and parts made in writing no later than eighteen (18) months after shipment. Defective items must be held for Seller's inspection and returned to the original f.o.b. point upon request. **THE FOREGOING IS EXPRESSLY IN LIEU OF ALL OTHER WARRANTIES WHATSOEVER, EXPRESS, IMPLIED AND STATUTORY, INCLUDING, WITHOUT LIMITATION, THE IMPLIED WARRANTIES OF MERCHANTABILITY AND FITNESS.**

B. Upon Buyer's submission of a claim as provided above and its substantiation, Seller shall at its option either (i) repair or replace its product, part or work at either the original f.o.b. point of delivery or at Seller's authorized service station nearest Buyer or (ii) refund an equitable portion of the purchase price.

C. This warranty is contingent upon Buyer's proper maintenance and care of Seller's products, and does not extend to normal wear and tear. Seller reserves the right to void warranty in event of Buyer's use of inappropriate materials in the course of repair or maintenance, or if Seller's products have been dismantled prior to submission to Seller for warranty inspection.

D. The foregoing is Seller's only obligation and Buyer's exclusive remedy for breach of warranty, and is Buyer's exclusive remedy hereunder by way of breach of contract, tort, strict liability or otherwise. In no event shall Buyer be entitled to or Seller liable for incidental or consequential damages. Any action for breach of this agreement must be commenced within one (1) year after the cause of action has accrued.