



TOLL FREE 1-800-392-0146

www.hoist-parts.com
parts@sisscohoist.com

SISSCO ONLINE HOIST PARTS DISTRIBUTION CENTER MANUALS



A Reputation for Service Since 1972
Certified WBE



Operating, Maintenance & Parts Manual

Model BCD4000

APPLICATION AND USE

INDUSTRIAL USE ONLY

The model BCD4000 Crane Kit can be used to construct bridge cranes with up to 4000 pounds rated load. The kit is intended for industrial use only and should not be used to lift, support, or otherwise transport people.

CRANE TRUCK DESIGN

The BCD4000 crane truck is designed to fit a 6 inch American Standard I-beam (3.33 inch flange width). With the use of spacer shims between the two sides of the crane truck, it may be adjusted to fit up to a 12 inch American Standard Beam (5.00 inch flange width). When ordered to fit a 6, 8, 10, or 12 inch I-beam, the crane kit includes a sufficient quantity of shims to fit the beam for which it was ordered.

The standard BCD4000 crane truck uses tapered tread wheels to fit American Standard I-beams. Trucks with flat tread wheels for Wide Flange or Patented Track are available on special order.

SPAN BEAM SIZING

The size of the I-beam required to provide adequate strength in the span beam depends on the rated load and the length of the span. Refer to Table 1 for the minimum beam size that should be used for various combinations of span and load rating.

INSTALLATION

PREPARATION

1. The first step of installing the bridge is to be sure that the runway beams are parallel. Runways should be parallel within 1/4 inch maximum. Setting the trucks with extra clearance between the beam flange and guide rollers to accommodate non-parallel beams will result in bridge skewing and binding.
2. I-beam dimensions can vary considerably from nominal handbook specifications. The flange width of the runway beams should be measured and the crane trucks adjusted with the provided shims so that the distance between the guide rollers is 1/4 inch more than the flange width. The shims, which are each 1/16 inch thick, should be placed between the truck halves, and the thru-bolts run up snug to check the setting.

TRUCK POSITIONING

1. Place the adjusted trucks on the runway beams. If the ends of the beams are accessible, the truck may be slipped over the end of the beam without disassembly. With the truck on the beam, loosen the thru-bolts to let the two truck halves position themselves so that all four wheels are contacting the beam. Tighten thru-bolts to 45 ft-lbs torque.
2. Position the trucks directly opposite one another on their runways. Be sure each truck is centered on its beam, not riding to one side. Carefully measure the distance between the eight holes for attaching the span beam to the crane trucks. Drill the top flange of the span beam to accept the 1/2 inch Grade 5 beam mounting bolts.

COFFING®

HOISTS

Bridge Crane Kit

- The span beam should be at least as long as the outside to outside distance between the two trucks, and should be equipped with stops to prevent the hoist and trolley from traveling beyond the center of either runway beam.
- Fasten the span beam to the trucks using the mounting hardware provided (See Figure 1). Double check that the span beam is perpendicular to the runway beams and that the trucks are centered on the runway beams. Tighten beam mounting bolts to 75 ft-lbs torque.

LONGER SPAN CRANES

- On longer span cranes it may be desirable to add diagonal braces between the span beam and the crane trucks as additional insurance against loss of truck alignment.
- Four pieces of 1/4 inch flat stock or small angle iron about three feet long may be welded or bolted diagonally between the bottom of the truck and the top of the span beam.

LOAD RATING

The load rating of the bridge should be stenciled or otherwise permanently and visibly marked on both sides of the span beam.

INSPECTION AND MAINTENANCE

PERIODIC INSPECTION

A regular inspection schedule should be established for the hoist on the crane. Inspect all parts of the crane at the same time as hoist inspection. Check for loose, cracked, or deformed parts. Refer to American National Standard (ANSI B30.11), "Monorails and Underhung Cranes" for complete crane inspection and testing procedures

LUBRICATION

All wheel bearings are permanently lubricated and sealed. No routine maintenance should be required.

WARNING

The designated load rating of the hoist or trolley should not exceed the rated load of the span beam (See Table 1).

Figure 1 - Hardware Replacement

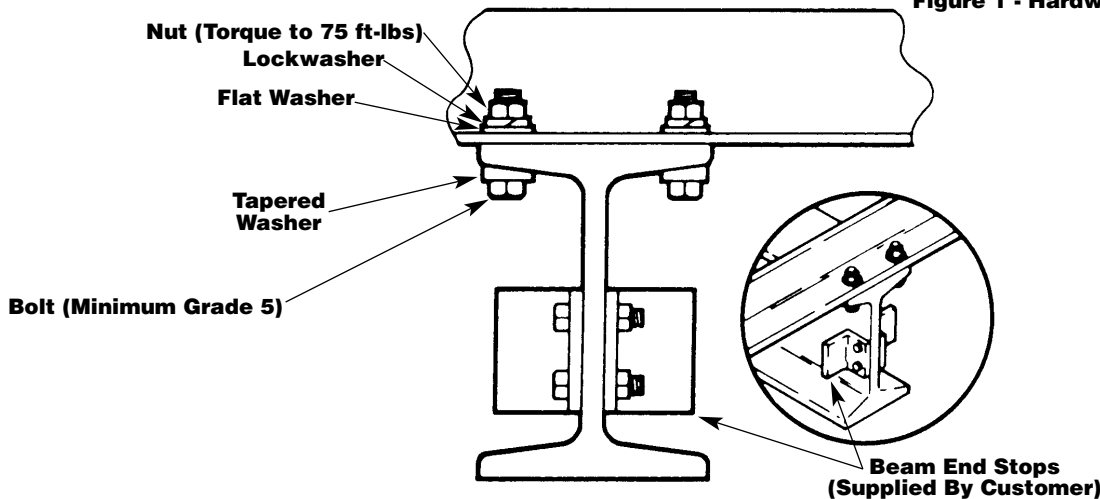

Table 1 - Span Beam Sizing

| Rated Load* (lbs) | 10 ft Span Beam Size** | 12.5 ft Span Beam Size | 15 ft Span Beam Size | 17.5 ft Span Beam Size | 20 ft Span Beam Size | 22.5 ft Span Beam Size | 25 ft Span Beam Size | 27.5 ft Span Beam Size | 30 ft Span Beam Size |
|-------------------|------------------------|------------------------|----------------------|------------------------|----------------------|------------------------|----------------------|------------------------|----------------------|
| 500 | 6" x 12.5# | 6" x 12.5# | 6" x 12.5# | 6" x 12.5# | 6" x 12.5# | 6" x 12.5# | 7" x 15.3# | 7" x 15.3# | 7" x 20# |
| 1000 | 6" x 12.5# | 7" x 15.3# | 7" x 15.3# | 7" x 15.3# | 7" x 20# | 8" x 18.4# | 8" x 23# | 10" x 25.4# | 10" x 25.4# |
| 2000 | 7" x 15.3# | 8" x 18.4# | 8" x 23# | 10" x 25.4# | 10" x 25.4# | 10" x 35# | 12" x 31.8# | 12" x 31.8# | 12" x 35# |
| 3000 | 8" x 23# | 10" x 25.4# | 10" x 35# | 12" x 31.8# | 12" x 35# | 15" x 42.9# | 15" x 42.9# | 15" x 42.9# | 15" x 42.9# |
| 4000 | 10" x 25.4# | 10" x 35# | 12" x 31.8# | 15" x 42.9# | 15" x 42.9# | 15" x 42.9# | 15" x 42.9# | - | - |

a* Chain hoist and trolley included in capacity. Loads are based on ASTM-A36 steel beams or equal.

**Beam weights are per foot of beam. Multiply weight figure shown by length (in feet) of span beam used, in computing total installed weight.

CAUTION: Be sure parallel tracks are sufficiently strong to withstand the capacities you intend to carry - including the weight of the span beam, bridge unit, hoist, trolley and other accessories. Use a minimum safety factor of 5:1. If in doubt, consult a qualified Structural Engineer.

COFFING® HOISTS

Country Club Road • P.O. Box 779
Wadesboro, NC 28170 U.S.A
Phone 800-477-5003 • 704-694-2156
Fax 800-374-6853