



TOLL FREE 1-800-392-0146

www.hoist-parts.com
parts@sisscohoist.com

SISSCO ONLINE HOIST PARTS DISTRIBUTION CENTER MANUALS



A Reputation for Service Since 1972
Certified WBE



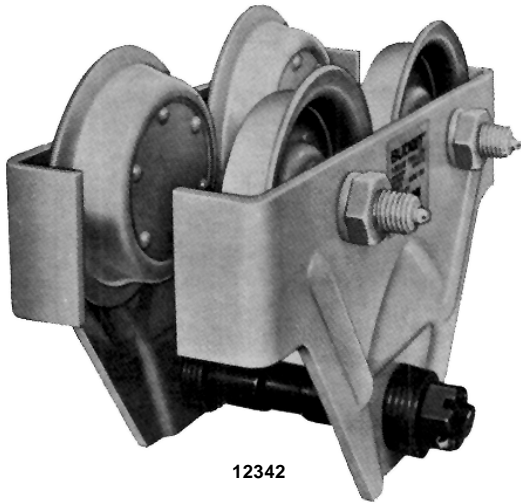

12342

BUDGIT®

P.O. Box 769
Muskegon, MI 49443-0769
Phone: 800 742-9269
Fax: 800 742-9270

BUDGIT® I-BEAM AND PATENTED TRACK TROLLEYS PUSH TYPE / HOOK SUSPENSION HAND GEARED / HOOK SUSPENSION 1/4 THRU 2 METRIC TON RATED LOADS

INSTRUCTIONS

These BUDGIT trolleys can be installed on I-beams or patented track as specified in chart below. Sufficient spacer washers are furnished with each trolley for the maximum flange width the trolley is designed to fit.

BEAM FLANGE WIDTHS THAT TROLLEYS WILL FIT

Rated Metric Load	Catalog Number	Minimum I-Beam Height (in)	Flange Widths (in)	
			Minimum	Maximum
1/4 Ton (550 lb.)	80 80WFA	4	2-5/8 5	4-5/8 7
1/2 Ton (1100 lb.)	81 81WFA	4	2-5/8 5	4-5/8 7
1 Ton (2200 lb.)	82 82WFA 82WFB	5	3 5 7	5 7 9
1 Ton (2200 lb.)	82G 82GWFA 82GWFB	5	3 5 7	5 7 9
1 Ton (2200 lb.)	900382	Patented Track	3-1/4	3-1/4
1-1/2 Ton (3300 lb.)	79 79WFA 79WFB	6	3-3/8 6 8	6 8 10
1-1/2 Ton (3300 lb.)	79G 79GWFA 79GWFB	6	3-3/8 6 8	6 8 10
2 Ton (4400 lb.)	83 83WFA 83WFB	6	3-3/8 6 8	6 8 10
2 Ton (4400 lb.)	83G 83GWFA 83GWFB	6	3-3/8 6 8	6 8 10
2 Ton (4400 lb.)	900383	Patented Track	3-1/4	3-1/4

Spark Resistant models (identified by "SR" suffix on Catalog No.) also fit above beam sizes.

INSTALLATION

To make sure that both side plates are held tightly in place, it is important that all spacer washers that come with trolley be used on cross pin.

To assemble trolley place a sufficient number of washers on cross pin so that when the trolley is on the beam and one pair of wheels are tight against the beam flange, as illustrated in "WASHER ARRANGEMENT" drawing, there will be not less than 1/8" nor more than 1/4" clearance between the opposite pair of wheels and the beam flange. Place all remaining washers on the cross pin, outside of trolley side plates, and install slotted hex nuts. Due to variations in the thickness of spacer washers, it may be necessary to omit a washer from one or both outside ends of the cross pin in order to install cotter pins.

On patented track trolley Catalog Number 900382, start with one washer inside and nine outside on each side. On patented track trolley Catalog Number 900383, start with three washers inside and ten outside on each side.

Tighten nuts securely on cross pin and align cotter pin slots with cotter pin holes. Insert cotter pins. Before securing cotter pins, carefully load trolley with maximum load to be handled (not exceeding rated capacity), then remove load and recheck nuts to make certain they are tight. Cotter pins should now be spread open to secure them.

⚠ WARNING

If cotter pins do not engage slots of nuts after the nuts are firmly tightened against the washers, the nuts may loosen and cause excessive wheel clearance which may allow the trolley to separate from the I-beam and result in injury to operator and others, including danger to life and limb, and damages to load and other property.

⚠ WARNING

If trolley is mounted on an open-end beam, end stops must be installed to prevent trolley from running off the end of the beam resulting in injury to operator and others including danger to life and limb, and damages to load and other property.

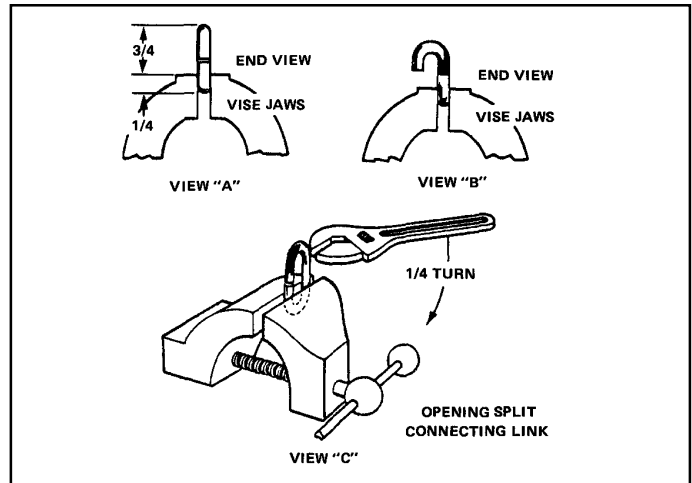
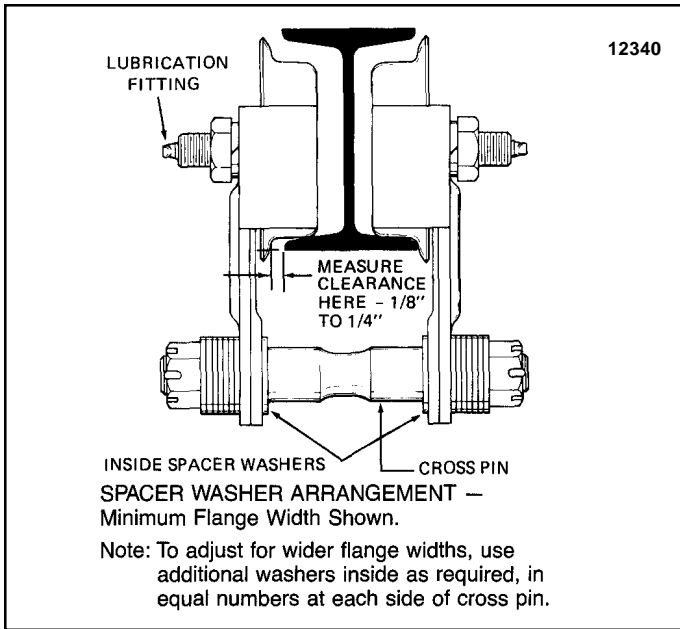

(3) After hand chain is desired length, then insert ends of chain on open link. Make sure there is no twist in the chain.

(4) Place wrench on top part of link, tighten jaws and twist back until link is closed.

OPERATING PRECAUTIONS

DO NOT load trolley beyond rated capacity.

DO NOT subject trolley to side loads. Always center trolley over load when hoisting.

DO NOT ram trolley into end stops, other trolleys, or any obstruction on beam. Improper and careless operation can result in a hazardous condition for operator and load.

ALWAYS be sure hoist suspension hook, clevis or hook adaptor is centered on cross pin, seated in recess on pin.

ALWAYS be sure load is clear of obstructions before traversing load and trolley.

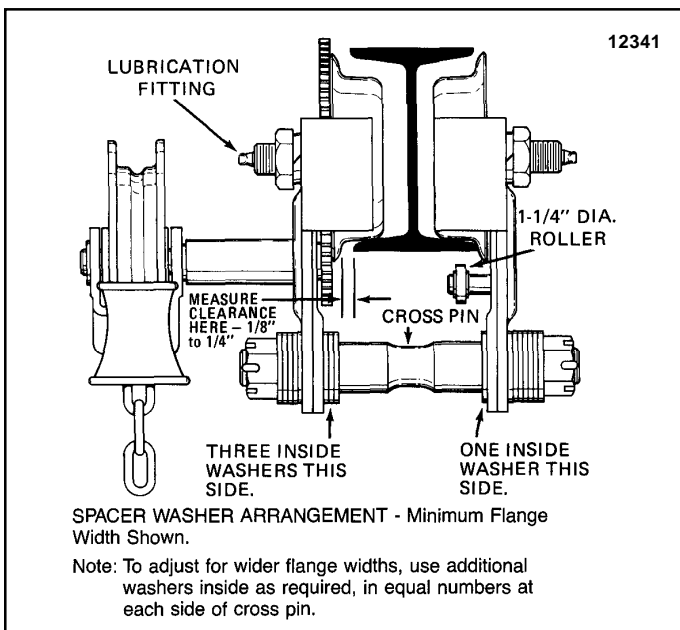

⚠ WARNING

These trolleys are not designed nor intended to be used to support or transport people or for supporting or transporting loads over people.

INSPECTION AND MAINTENANCE

Inspect the trolley on a regular maintenance schedule. Check to make sure wheel axle nuts and cross pin nuts are tight and cotter pins are in place. Check gear teeth on drive wheels and pinion on hand geared trolleys for wear or damage. Check wheel tread surfaces for wear or damage. Check side plates for any evidence of overload or damage. Replace any worn or damaged parts using only factory approved replacement parts.

Lubricate wheel bearings thru pressure fittings in wheel axles with light grease.

REPLACEMENT PARTS

When ordering replacement parts, the trolley model number must be furnished with order. Order all replacement parts from an authorized BUDGIT Repair Station or from a BUDGIT Hoist Distributor. Do not order replacement parts from the factory.

INFORMATION CONTAINED HEREIN SUBJECT TO CHANGE WITHOUT NOTICE.

On hand geared trolleys two anti-tilt rollers are provided to allow trolley to fit the full specified range of I-beam sizes. Trolley is assembled with the small roller (1" dia.) which is suitable for Standard I-beam sizes from 10" up to the largest specified for the trolley. For I-beams smaller than 10", substitute the larger roller (1-1/4" dia.) by removing the outer roller retaining ring and replacing the smaller roller. For other than Standard I-beams measure the beam flange thickness and allow not less than 1/16" clearance between roller and bottom of beam flange.

HAND CHAIN LENGTH FOR HAND GEARED TROLLEYS

Trolley is furnished with 9'-6" hand chain drop. If hand chain is of improper length (chain should hang about 2'-6" above floor), modify its length as follows:

(1) Insert split connecting link in a vise so that three-quarters of link is above the top of vise jaws as shown in view A. (2) Place wrench on top part of link, tighten jaws, then twist link open wide enough to remove ends of hand chain from split link. See view B.

To enable us to expedite your parts order, always give Catalog Number, Model Number and Capacity, found on hoist nameplate.

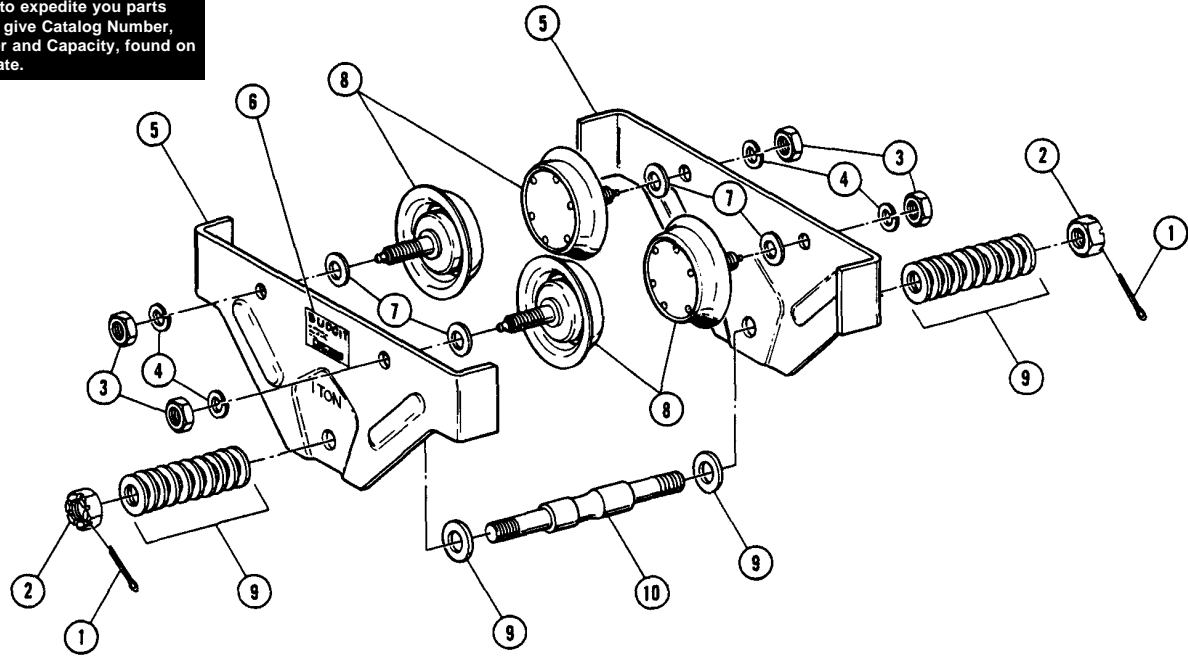

12338B

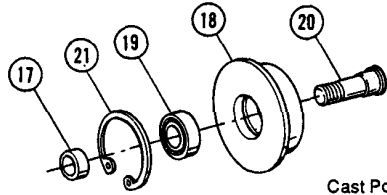

Cast Polyamide Wheels Only

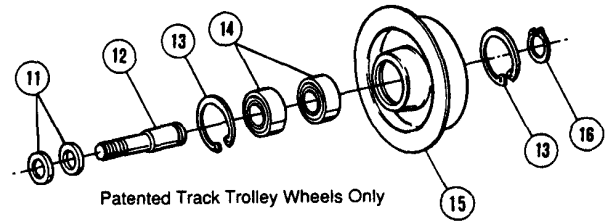

Patented Track Trolley Wheels Only

Ref. No.	Part Description	Key Numbers									
		1/4 & 1/2 Metric Ton		1 Metric Ton				1-1/2 & 2 Metric Tons			
			Qty.	I-beam	Qty.	Pat. Trk.	Qty.	I-beam	Qty.	Pat. Trk.	Qty.
1	Cotter Pin	BT-1501	2	BT-1513	2	BT-1513	2	BT-1526	2	BT-1526	2
2	Slotted Hex Nut	BT-1502	2	BT-1514	2	BT-1514	2	BT-1527	2	BT-1527	2
3	Hex Jam Nut	BT-1503	4	BT-1515	4	BT-1515	4	BT-1515	4	BT-1515	4
4	Lockwasher	BT-1504	4	BT-1516	4	BT-1516	4	BT-1516	4	BT-1516	4
5	Side Plate - Plain Bumpers Vinyl Covered Bumpers	BT-1505	2	BT-1517	2	BT-1570	2	BT-1528	2	BT-1571	2
6	Adhesive Nameplate	BT-1507	1	BT-1507	1	BT-1507	1	BT-1507	1	BT-1507	1
7	Spacer Washer	BT-1536	4	BT-1519	4	--	--	BT-1519	4	--	--
8	Wheel & Axle Assembly - Standard Model Spark Resistant Model	BT-1508	4	BT-1520	--	BT-1572	4	BT-1530	4	BT-1573	4
9	Spacer Washer	BT-1509	4	BT-1521	4	--	--	BT-1531	4	--	--
	Cat. Nos. 82, 82SR & 900382	--	--	BT-1522	20	BT-1522	20	--	--	--	--
	Cat. Nos. 79, 79SR, 83, 83SR & 900383	--	--	--	--	--	--	BT-1532	26	BT-1532	26
	Others	BT-1510	22	BT-1522	22	--	--	BT-1532	22	--	--
10	Cross Pin - 7-9/16" lg. for 2-5/8" to 4-5/8" flange 9-7/8" lg. for 5" to 7" flange 8-1/4" lg. for 3" to 5" flange 10-3/8" lg. for 5" to 7" flange 12-3/8" lg. for 7" to 9" flange 8-3/4" lg. for 3-3/8" to 6" flange 10-3/4" lg. for 6" to 8" flange 12-3/4" lg. for 8" to 10" flange	BT-1511	1	--	--	--	--	--	--	--	--
		BT-1512	1	--	--	--	--	--	--	--	--
		--	--	BT-1523	1	BT-1523	1	--	--	--	--
		--	--	BT-1524	1	--	--	--	--	--	--
		--	--	BT-1525	1	--	--	--	--	--	--
		--	--	--	--	--	--	BT-1533	1	BT-1533	1
		--	--	--	--	--	--	BT-1534	1	--	--
		--	--	--	--	--	--	BT-1535	1	--	--
11	Spacer Washer	--	--	--	--	BT-1574	8	--	--	BT-1574	8
12	Axle	--	--	--	--	BT-1575	4	--	--	BT-1576	4
13	Retaining Ring	--	--	--	--	BT-1577	8	--	--	BT-1577	8
14	Ball Bearing	--	--	--	--	BT-1578	4	--	--	BT-1578	4
15	Wheel	--	--	--	--	BT-1579	4	--	--	BT-1580	4
16	Retaining Ring	--	--	--	--	BT-1581	4	--	--	BT-1581	4
17	Spacer	--	--	BT-1582	4	--	--	--	--	--	--
18	Wheel - Polyamide	--	--	BT-1583	4	--	--	--	--	--	--
19	Ball Bearing	--	--	BT-1584	4	--	--	--	--	--	--
20	Axle	--	--	BT-1585	4	--	--	--	--	--	--
21	Retaining Ring	--	--	BT-1586	4	--	--	--	--	--	--

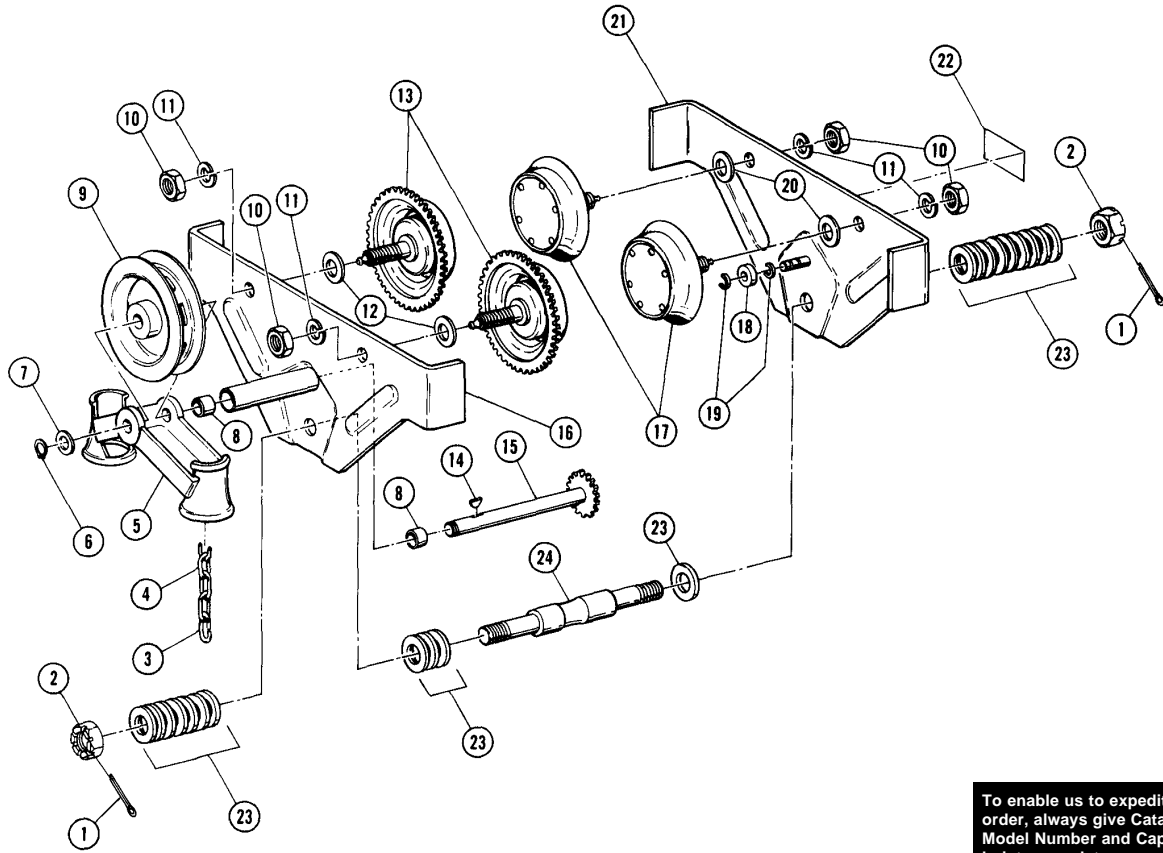

To enable us to expedite your parts order, always give Catalog Number, Model Number and Capacity, found on hoist nameplate.

Ref. No.	Part Description	Qty. Required	Key Numbers	
			1 Metric Ton	1-1/2 & 2 Metric Ton
1	Cotter Pin	2	BT-1 513	BT-1526
2	Slotted Hex Nut	2	BT 1514	BT 1527
3	Connecting Link - Std. Model	1	BT 1536	BT 1536
	- S. R. Model	1	BT 1537	BT-1 537
4	Hand Chain - Std. Model	**	BT 1538	BT 1538
	- S. R. Model	**	BT 1539	BT 1539
5	Chain Wheel Guide	1	BT 1540	BT 1540
6	Retaining Ring	1	BT 1541	BT 1541
7	Spacer Washer	1	BT 1542	BT 1542
8	Bushing	2	BT 1543	BT 1543
9	Hand Chain Wheel	1	BT 1544	BT-1 544
10	Hex Jam Nut	4	BT 1515	BT 1515
11	Lockwasher	4	BT 1516	BT 1516
12	Spacer Washer	2	BT-1545	BT-1545
13	Geared Wheel & Axle Assembly - Standard Model	2	BT-1 546	BT 1559
	- Spark Resistant Model	2	BT 1547	BT 1560
14	Woodruff Key (No. 6)	1	BT-1 548	BT 1548
15	Pinion & Shaft Assembly	1	BT 1549	BT 1549
16	Side Plate Assembly - Geared Side - With Plain Bumpers	1	BT 1550	BT 1561
	- With Vinyl Covered Bumpers	1	BT 1551	BT 1562
17	Plain Wheel & Axle Assembly - Standard Model	2	BT 1520	BT 1530
	- Spark Resistant Model	2	BT 1521	BT 1531
18	Anti Tilt Roller - 1" Dia. - Std. Model	1	BT 1552	BT 1552
	- 1" Dia. - S. R. Model	1	BT 1553	BT 1553
	- 1-1/4" Dia. - Std. Model	1	BT-1 554	BT 1554
	- 1-1/4" Dia. - S. R. Model	1	BT-1 555	BT 1555
19	Retaining Ring	2	BT-1 556	BT-1 556
20	Spacer Washer	2	BT 1519	BT-1 519
21	Side Plate Assembly - Plain Side - With Plain Bumpers	1	BT 1557	BT 1563
	- With Vinyl Covered Bumpers	1	BT-1558	BT-1564
22	Adhesive Nameplate	1	BT-1 507	BT 1507
23	Spacer Washer	*20	BT 1522	BT 1532
24	Cross Pin - 8-1/4" lg. for 3" to 5" flange	1	BT 1523	--
	- 10-3/8" lg. for 5" to 7" flange	1	BT 1524	--
	- 12-3/8" lg. for 7" to 9" flange	1	BT 1525	--
	- 8-3/4" lg. for 3-3/8" to 6" flange	1	--	BT 1533
	- 10-3/4" lg. for 6" to 8" flange	1	--	BT 1534
	- 12-3/4" lg. for 8" to 10" flange	1	--	BT 1535

*Above quantity is for Cat. 82G (1 ton) trolleys. Cat. 79G (1-1/2 ton) and 83G (2 ton) trolleys require a quantity of 26; trolley with "WFA" and "WFB" suffixes require 22.
 **Bulk chain. Specify length required. Length equals two times chain drop plus one foot.