



TOLL FREE 1-800-392-0146

www.hoist-parts.com
parts@sisscohoist.com

SISSCO ONLINE HOIST PARTS DISTRIBUTION CENTER MANUALS



A Reputation for Service Since 1972
Certified WBE



Operating, Maintenance & Parts Manual

Lineman's Hoist



Model Numbers

322B

344B

322DB

344DB

322CB

344CB

322DHB

344DHB

Follow all instructions and warnings for inspecting, maintaining and operating this hoist.

The use of any hoist presents some risk of personal injury or property damage. That risk is greatly increased if proper instructions and warnings are not followed. Before using this hoist, each operator should become thoroughly familiar with all warnings, instructions, and recommendations in this manual. Retain this manual for future reference and use.

Forward this manual to the hoist operator.

Failure to operate the equipment as directed in the manual may cause injury.

Should you have any questions or have problems with this product, please call Little Mule at **(800) 477-5003**

Before using the hoist, fill in the information below:

Model No. _____

Serial No. _____

Purchase Date _____



SAFETY PRECAUTIONS

Each Little Mule Lineman's Hoist is built in accordance with the specifications contained herein and at the time of manufacture complies with our interpretation of applicable sections of *American Society of Mechanical Engineers Code (ASME) B30.21. *Copies of this Standard can be obtained from ASME Order Department, 22 Law Drive, Box 2300, Fairfield, NJ 07007-2300, U.S.A.

WARNING

Improper operation of a hoist can create a potentially hazardous situation which, if not avoided, could result

1. **NOT** operate a malfunctioning or unusually performing hoist.
2. **NOT** operate the hoist until you have thoroughly read and understood the manufacturer's Operating and Maintenance Instructions or Manuals.
3. **NOT** operate a hoist which has been modified without the manufacturer's approval or certification to be in conformity with applicable OSHA regulations.
4. **NOT** lift or pull more than rated load for the hoist.
5. **NOT** use damaged hoist or hoist that is NOT working properly.
6. **NOT** use hoist with damaged or excessively worn strap.
7. **NOT** operate with any lever extension (cheater bar).
8. **NOT** attempt to "free-wheel" the hoist while a load is applied.
9. **NOT** use the hoist to lift, support, or transport people.
10. **NOT** lift loads over people and should always make sure all personnel remain clear of the supported load.
11. Protect the hoist's strap from weld splatter or other damaging contaminants.
12. **NOT** operate hoist when it is restricted from forming a straight line from hook to hook in the direction of loading.
13. **NOT** use hoist strap as a sling or wrap around load.
14. **NOT** apply the load to the tip of the hook or to the hook latch.
15. **NOT** apply load unless strap is properly seated in the drum.
16. **NOT** leave load supported by the hoist unattended unless specific precautions have been taken.
17. **NOT** remove or obscure the warnings on the hoist.
18. **NOT** operate a hoist which has NOT been securely attached to a suitable support.
19. **NOT** operate a hoist unless load slings or other approved attachments are properly sized and seated in the hook saddle.
20. **NOT** lift loads that are NOT balanced and that the holding action is NOT secure, taking up slack carefully.
21. **NOT** operate a hoist unless all persons are and remain clear of the supported load.
22. Report malfunctions or unusual performances of a hoist, after it has been shut down until repaired.
23. **NOT** operate a hoist on which the safety placards or decals are missing or illegible.
24. Be familiar with operating controls, procedures, and warnings.

CAUTION

Improper operation of a hoist can create a potentially hazardous situation which, if not avoided, could result in minor or moderate injury. To avoid such a potentially hazardous situation, THE OPERATOR SHALL:

1. Maintain a firm footing or be otherwise secured when operating the hoist.
2. Use hook latches. Latches are to retain slings, chains, etc. under slack conditions only.
3. Make sure the hook latches are closed and not supporting any parts of the load.
4. Make sure the load is free to move and will clear all obstructions.
5. Avoid swinging the load or hook.
6. Avoid lever "fly-back" by keeping a firm grip on the lever until operating stroke is completed and the lever is at rest.
7. Inspect the hoist regularly, replace damaged or worn parts, and keep appropriate records of maintenance.
8. Use the hoist manufacturer's recommended parts when repairing the unit.
9. **NOT** use the hoist load limiting or warning device to measure load.
10. **NOT** operate except with manual power.
11. **NOT** permit more than one operator to pull on lever at the same time. More than one operator is likely to cause hoist overload.
12. **NOT** allow your attention to be diverted from operating the hoist.
13. **NOT** allow the hoist to be subjected to sharp contact with other hoists, structures, or objects through misuse.
14. **NOT** adjust or repair the hoist unless qualified to perform such adjustments or repairs.

TABLE OF CONTENTS

Safety Precautions	1
Safety Information	2
Hoist Specifications	2
Operation	2
Maintenance	2
Inspection and Maintenance Check List	4
Replacement Parts List	5
Warranty	Back Cover

SAFETY INFORMATION

WARNING:
ELECTRICAL SHOCK MAY RESULT IN
SERIOUS INJURY OR DEATH:

The web strap on this hoist is **NOT** a rated insulating member. When clean and dry, the strap may have dielectric properties typical of nylon or polyester fibers. The non-metallic handle and webbing provide an extra measure of safety for use around energized power lines. **Use an appropriate insulating member in series with hoist to achieve proper working distances per OSHA Regulation Subpart V, 1926.950 or your company work practices.** When the handle swings closer to energized conductors than OSHA safe working distances or company practices permit, use appropriate clothing and rubber gloves for rated voltages.

HOIST SPECIFICATIONS

All web strap hoist models are designed for lifting and pulling loads up to rated capacities listed on the hoist nameplate. Features include a winding wheel for taking up slack or free stripping of the strap and a handle tip designed to bend before any mechanical part of the hoist is subjected to damaging overload. The handle may be inserted into the U-Frame socket from either direction to facilitate use in confined areas or to allow the operator to pull against the load under unusual conditions. A double, interlocking pawl system provides positive load control at all times. Hot-stick rings on levers and hooks increase safety and utility. Refer to Table 1.

OPERATION

LIFTING OR PULLING

Place reversing lever in up position, engaging the loading pawl against the ratchet teeth. Work handle as required to get desired lift or tension. Handle may be inserted into either end of the U-frame socket to enable user to work in restricted areas. Never use a "cheater" bar or handle other than those approved by the manufacturer.

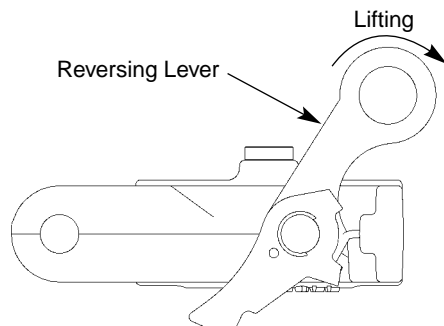

Figure 1

CAUTION

Rig hoist properly so that the hoist is free to align with the direction of pull. Avoid side loading. Hoist frame should not bear against anything and should be free to align with hooks.

LOWERING

Place the reversing lever in the down position and operate the handle to its extreme down position until the load is removed from the holding pawl. As the handle is slowly released, the load will be lowered or released by one notch. To continue lowering repeat this operation. The lowering of heavy loads is easier if quick (sharp) downward handle motion is used.

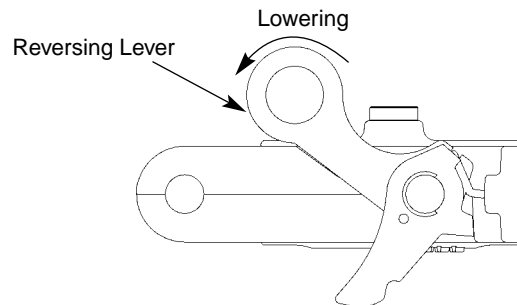

Figure 2

FREE-WHEELING

Before attempting to free-wheel make certain the hoist is unloaded. To release the strap for free-wheeling, the reversing lever must first be in the down position. Press the free-wheel lever or stroke the handle until the loading pawl contacts the guide pin (Figure 5, Ref. No. 4). The strap may now be stripped from the drum to facilitate more rapid positioning while attaching to the object to be pulled or lifted. Neither of these methods will work with 10 lbs. or more load on the hoist. Similarly, excess slack may be quickly and easily rewound on the drum using the winding wheel.

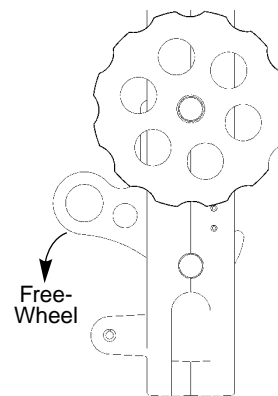

Figure 3

MAINTENANCE

Maintenance of the hoist is normally limited to cleaning and lubrication. The hoist should always be lubricated following each cleaning operation to replace any lubricants that were washed away.

CLEANING

Under normal use, minimum cleaning is required. Clean the metal parts and web strap with soap or detergent and water. Allow the web strap to dry thoroughly before using hoist.

LUBRICATION

Lubricate the pawls and ratchet wheel sparingly with a light grease. Apply a drop of clean oil to points where shafts rotate. Caution must be exercised to avoid getting lubricants on the web strap. The following parts should be lubricated as follows:

- a. Pawls and ratchet teeth should be lubricated weekly with a light grease.
- b. Pawl shafts, bearings, bottom block shaft and hook swivel should be lubricated weekly using SAE 20-30 Gear Oil.

The above lubrication schedule is based on a hoist operating in normal environment conditions. Hoists operating in adverse environments should be lubricated more frequently.

FREQUENT INSPECTIONS

In addition to performing all the frequent inspections listed under FREQUENT INSPECTION on Figure 4, visual observations should be conducted during regular service for any damage or evidence. Any deficiencies shall be carefully examined and determination made as to whether they constitute a hazard as follows:

- a. Check all functional operating mechanisms for maladjustment interfering with proper operation.
- b. Check all hooks and latches for deformation, chemical damage, cracks and wear.
- c. Check all hook latches for proper attachment and operation.
- d. Check levers for bends, cracks or other damage.
- e. Check for damage to the support for the hoist.

Web Strap Inspection

All web straps should be visually inspected by the operator or other designated person at the start of each shift.

These visual observations should be concerned with discovering gross damage, such as that listed below, which may be an immediate hazard:

- a. melting or charring
- b. acid or caustic burns
- c. weld spatter
- d. broken stitching
- e. cuts or tears
- f. damaged eyes
- g. abrasive wear
- h. knots

PERIODIC INSPECTIONS

In addition to performing all the periodic inspections listed under PERIODIC INSPECTION on Figure 4, the following should be conducted:

- a. A designated person shall determine whether conditions found during inspection constitute a hazard and whether disassembly is required.
- b. Check fasteners for evidence of loosening.
- c. Check web strap, suspension frame, levers, yokes, shafts, pins, rollers and locking and clamping devices for evidence of wear, corrosion, cracks and distortion.

Web Strap Inspection

Periodic inspections shall be performed by an appointed person. This inspection shall cover the entire length of the web strap. Special care should be taken when inspecting sections for rapid deterioration, such as the following:

- a. Sections in contact with saddles, equalizer sheaves, or other sheaves where web strap travel is limited.
- b. Sections at or near terminal ends where broken threads or cuts may be evident.
- c. Sections subject to reverse bends.
- d. Sections that are normally hidden during visual inspection, such as sections passing over sheaves.

Table 1 - Specifications

Model No.	Single Line			Double Line			Web Strap Length (ft)	Handle Length (in)	Ship Weight (lbs)
	Capacity (lbs)	Lift (ft)	Hook to Hook (Min.) (in)	Capacity (lbs)	Lift (ft)	Hook to Hook (Min.) (in)			
322B	1500	14	20	3000	7	23	15	24	12½
322CB	1500	14	23	3000	7	27½	15	24	12½
322DB	1500	14	20	3000	7	23	15	24	13
322DHB	1500	14	22	3000	7	26	15	24	13
344B	2000	11	20	4000	5½	23	12	30	12½
344CB	2000	11	23	4000	5½	27½	12	30	12½
344DB	2000	11	20	4000	5½	23	12	30	13
344DHB	2000	11	22	4000	5½	26	12	30	13

DB Includes Hot-Stick Rings on all hooks and handle assembly.

CB Includes Swivel-Type Gate Latch on all hooks.

DHB Includes Hot-Stick-Type Gate Latches on all hooks as well as Hot-Stick Rings on all hooks and handle assembly.

Country Club Road
P.O. Box 779
Wadesboro, NC 28170 USA
TEL: (800) 477-5003
FAX: (800) 374-6853

**INSPECTION AND MAINTENANCE CHECK LIST
LEVER OPERATED STRAP HOIST**

Type of Hoist _____ Capacity (Tons) _____
Location / Crew / Truck _____ Date Placed in Service _____
Manufacturer _____ Manufacturer's Serial No. _____

Item	Normal Service		Heavy Service		Severe Service		Remarks
	Visual Monthly	Record Yearly	Visual Weekly	Record 6 Months	Visual Daily	Record Monthly	
FREQUENT INSPECTION							
All functional mechanisms for proper operation	*		*		*		
Hooks and latches for deformation, chemical damage, cracks & wear (See ASME B30.10)	*		*		*		
Hook latch operation	*		*		*		
Web strap (See Web Strap Inspection)	*		*		*		
Levers for bends, cracks, etc.	*		*		*		
Hoist support for damage	*		*		*		
PERIODIC INSPECTION							
Evidence of loose pins, nuts or rivets		**		***		***	
Evidence of worn, corroded, cracked or distorted parts such as suspension frame, levers, web strap attachments, yokes, shafts, pins and rollers		**		***		***	
Evidence of damage to hook retaining nuts and pins		**		***		***	
Evidence of worn pawls, cams or ratchet; corroded, stretched or broken springs		**		***		***	
Warning label		**		***		***	
End connections and terminations of web strap		**		***		***	

*Visual inspection by operator or other designated personnel.
**Visual inspection by designated person of conditions.
***Visual inspection by designated person of conditions unless conditions indicate that disassembly should be done to permit detailed inspection.

NORMAL SERVICE - Weekly usage
HEAVY SERVICE - Daily usage
SEVERE SERVICE - Daily usage and/or in severe weather conditions (rain, snow, ice, etc.)

NOTE: This inspection and maintenance check list is in accordance with our interpretation of the requirements of the Safety Standard for Manually Lever Operated Hoists ASME B30.21. It is, however, the ultimate responsibility of the employer/user to interpret and adhere to the applicable requirements of this safety standard.

Figure 4 — Recommended Inspection and Maintenance Check List



For replacement parts, call 1-800-477-5003
 Please have the following information ready:
 -Model number
 -Serial number (if any)
 -Part description and number as shown in parts list

Figure 5 - Base Hoist

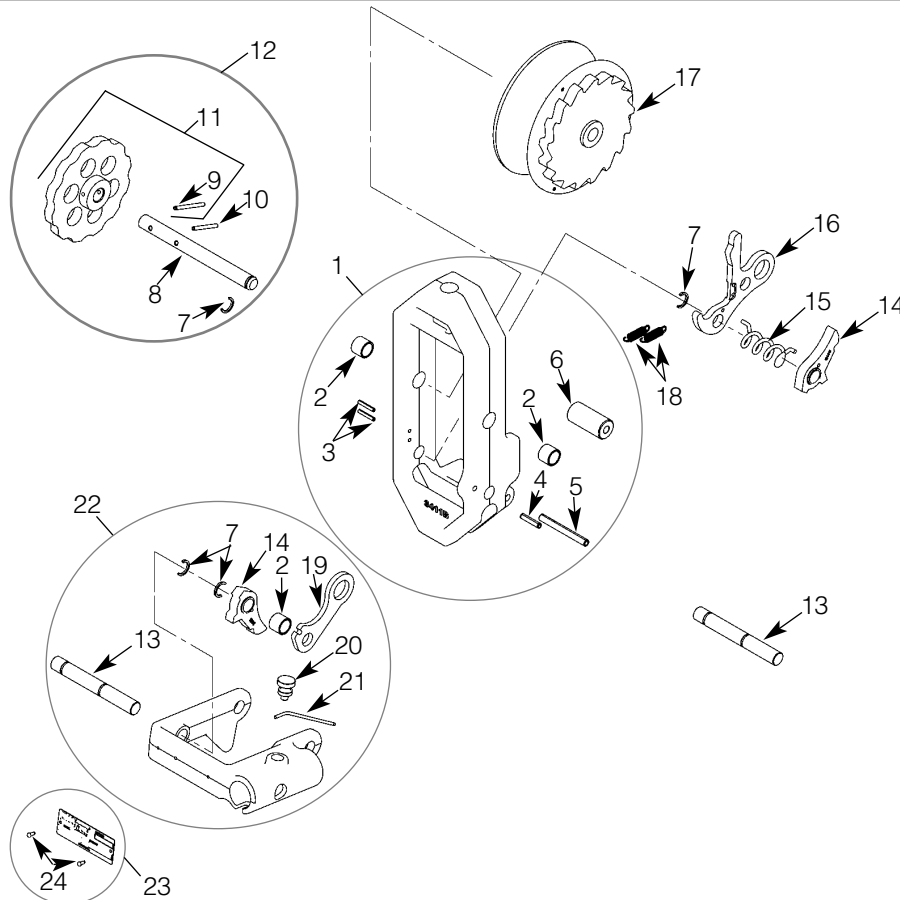

Parts List for Base Hoist

Ref No.	Description	Part No.	Qty	Ref No.	Description	Part No.	Qty
1	Main Frame Assembly	LG3411B	1	13	Pawl Shaft	445B	2
2	Bushing	LM12	3	14	Pawl	241B	2
3	Pin, 1/8 X .88	H5250	2	15	Pawl Spring	23L2	1
4	Pin, 3/16 X 1.00	H5265	1	16	Free-Wheel Lever	279B	1
5	Pin, 1/4 X 2.50	H5242	1	17	Strap Drum	3470B	1
6	Strap Roller	3427	1	18	Return Spring	23L1	2
7	Retaining Ring	H5596	4	19	Reversing Lever	47B	1
8	Drum Shaft	472B	1	20	Handle Lock	51	1
9	Pin, 1/8 X 1.25	73-1	1	21	Reversing Spring	42	1
10	Pin, 1/8 X 1.00	H5251	1	22	U-Frame Assembly	446B	1
11	Winding Wheel Assembly	32	1	23	Name Plate Kit	676L1K	1
12	Drum Shaft Assembly	LG107B	1	24	Drive Screw	H2861P	2

For replacement parts, call 1-800-477-5003
 Please have the following information ready:
 -Model number
 -Serial number (if any)
 -Part description and number as shown in parts list

Figure 6 - Models 322B & 344B

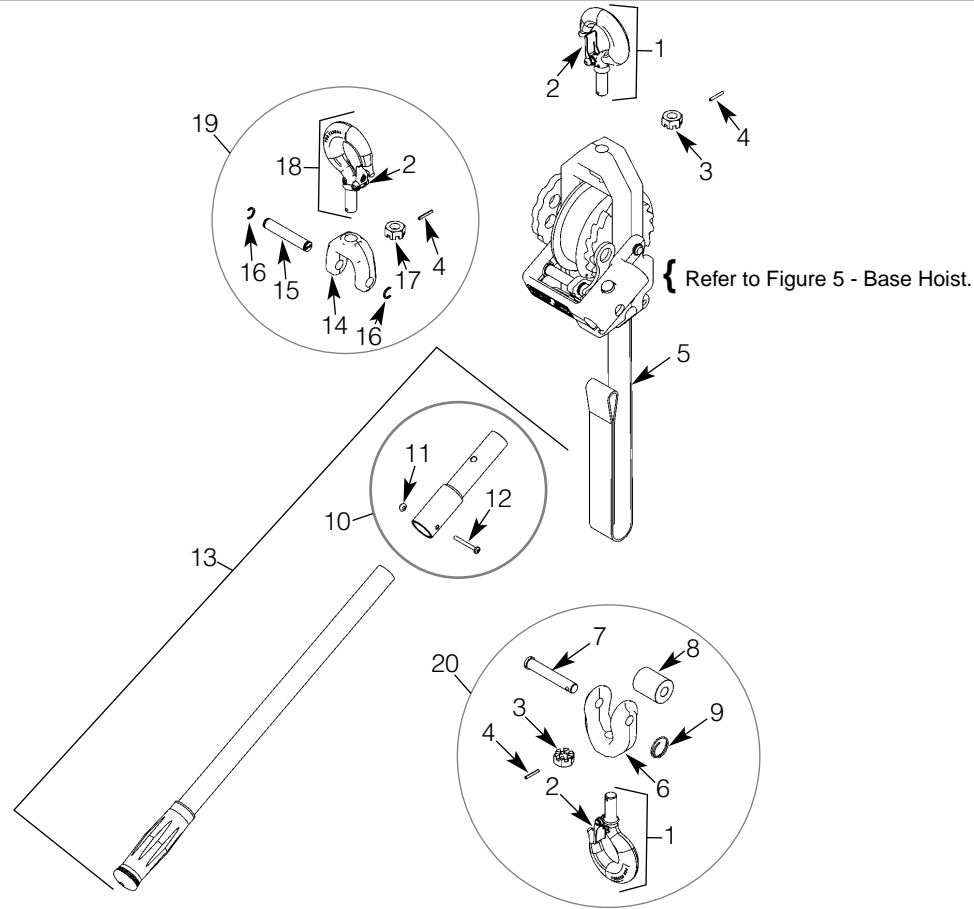

Parts List for Models 322B & 344B

Ref. No.	Description	Model 322B	Model 344B	Qty
1	Hook & Latch Assembly	3M003C01S	3M004C09S	2
2	Latch Kit	10A	10A	3
3	Nut	LM16	H3986P	2
4	Pin, 1/8 X .88	H5250	H5250	3
5	Strap	3471/15*	372/12**	1
6	Yoke	391	392	1
7	Quick Connect Pin	L18-1	L18-1	1
8	Roller	3495	3495	1
9	Quick Connect Ring	L18-3	L18-3	1
10	Handle Tip Kit	350K	350K	1
11	Nut	H3941	H3941	1
12	Screw	H2753	H2753	1
13	Handle Assembly	2450B	3050B	1
14	Yoke	LM3433	LM3433	1
15	Shaft	396B	396B	1
16	Retaining Ring	H5596	H5596	2
17	Nut	LM16	LM16	1
18	Hook & Latch Assembly	3M003C01S	3M003C01S	1
19	Hook & Yoke Assembly	335B	335B	1
20	Hook & Yoke Assembly	399B	3499B	1
†	Warning Decal (Not Shown)	649040344	649040344	1

* Yellow, 15' Long

** Blue, 12' Long

For replacement parts, call 1-800-477-5003
 Please have the following information ready:
 -Model number
 -Serial number (if any)
 -Part description and number as shown in parts list

Figure 7 - Models 322DB & 344DB

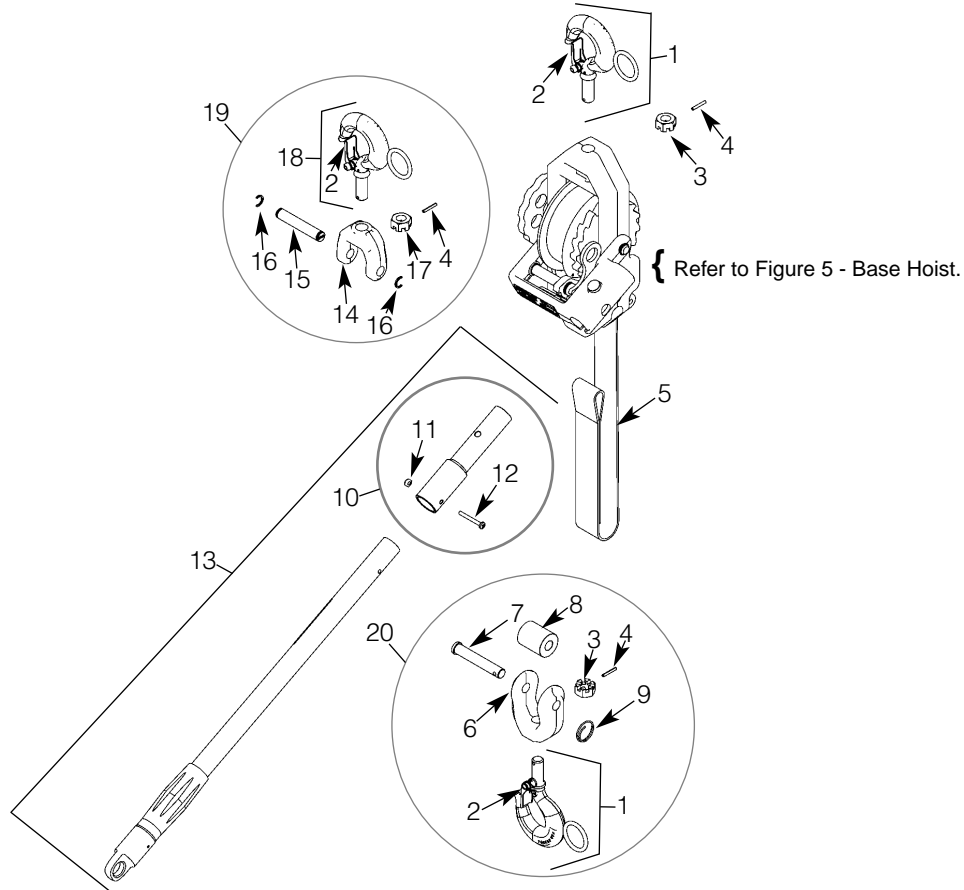

Parts List for Models 322DB & 344DB

Ref. No.	Description	Model 322DB	Model 344DB	Qty
1	Hook & Latch Assembly	3M003C02S	3M004C02S	2
2	Latch Kit	10A	10A	3
3	Nut	LM16	H3986P	2
4	Pin, 1/8 X .88	H5250	H5250	3
5	Strap	3471/15*	372/12**	1
6	Yoke	391	392	1
7	Quick Connect Pin	L18-1	L18-1	1
8	Roller	3495	3495	1
9	Quick Connect Ring	L18-3	L18-3	1
10	Handle Tip Kit	350K	350K	1
11	Nut	H3941	H3941	1
12	Screw	H2753	H2753	1
13	Handle Assembly	2450DB	3050DB	1
14	Yoke	LM3433	LM3433	1
15	Shaft	396B	396B	1
16	Retaining Ring	H5596	H5596	2
17	Nut	LM16	LM16	1
18	Hook & Latch Assembly	3M003C02S	3M003C02S	1
19	Hook & Yoke Assembly	335DB	335DB	1
20	Hook & Yoke Assembly	399DB	3499DB	1
†	Warning Decal (Not Shown)	649040344	649040344	1

* Yellow, 15' Long

** Blue, 12' Long

For replacement parts, call 1-800-477-5003
 Please have the following information ready:
 -Model number
 -Serial number (if any)
 -Part description and number as shown in parts list

Figure 8 - Models 322CB & 344CB

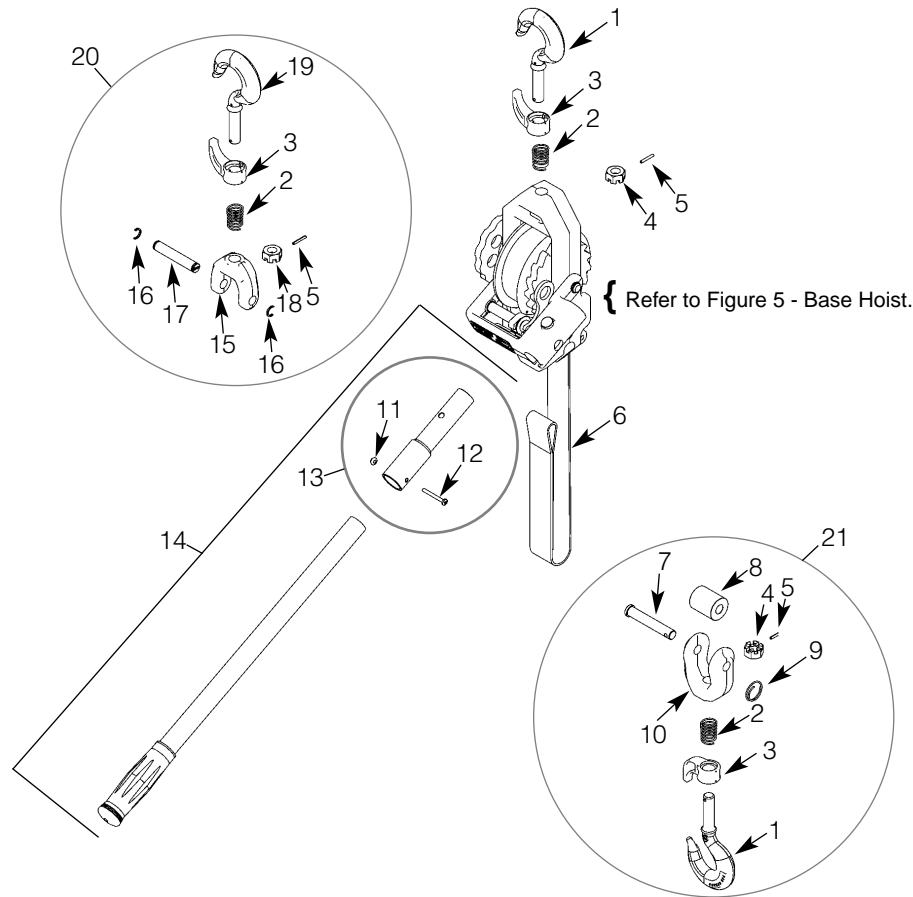

Parts List for Models 322CB & 344CB

Ref. No.	Description	Model 322CB	Model 344CB	Qty
1	Hook	324PGH4	324PGH7	2
2	Spring	324DH2-3	324DH2-3	3
3	Gate Latch	324PGH3	324PGH3	3
4	Nut	LM16	H3986P	2
5	Pin, 1/8 X .88	H5250	H5250	3
6	Strap	3471/15*	372/12**	1
7	Quick Connect Pin	L18-1	L18-1	1
8	Roller	3495	3495	1
9	Quick Connect Ring	L18-3	L18-3	1
10	Yoke	391	392	1
11	Nut	H3941	H3941	1
12	Screw	H2753	H2753	1
13	Handle Tip Kit	350K	350K	1
14	Handle Assembly	2450B	3050B	1
15	Yoke	LM3433	LM3433	1
16	Retaining Ring	H5596	H5596	2
17	Shaft	396B	396B	1
18	Nut	LM16	LM16	1
19	Hook	324PGH4	324PGH4	1
20	Hook & Yoke Assembly	335CB	335CB	1
21	Hook & Yoke Assembly	399CB	3499CB	1
†	Warning Decal (Not Shown)	649040344	649040344	1

* Yellow, 15' Long

** Blue, 12' Long

For replacement parts, call 1-800-477-5003
 Please have the following information ready:
 -Model number
 -Serial number (if any)
 -Part description and number as shown in parts list

Figure 9 - Models 322DHB & 344DHB

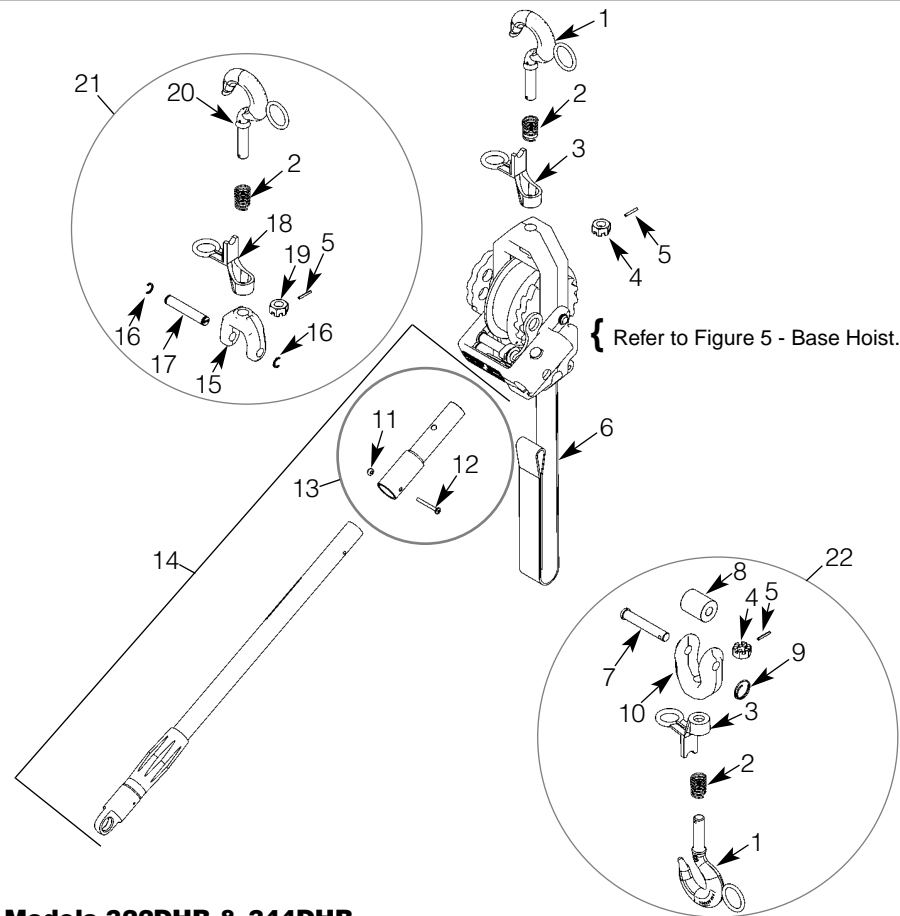

Parts List for Models 322DHB & 344DHB

Ref. No.	Description	Model 322DHB	Model 344DHB	Qty
1	Hook	3M003C03	3M004C06	2
2	Spring	324DH2-3	324DH2-3	3
3	Gate Latch	324DH9	324DH10	2
4	Nut	LM16	H3986P	2
5	Pin, 1/8 X .88	H5250	H5250	3
6	Strap	3471/15*	372/12**	1
7	Quick Connect Pin	L18-1	L18-1	1
8	Roller	3495	3495	1
9	Quick Connect Ring	L18-3	L18-3	1
10	Yoke	391	394	1
11	Nut	H3941	H3941	1
12	Screw	H2753	H2753	1
13	Handle Tip Kit	350K	350K	1
14	Handle Assembly	2450DB	3050DB	1
15	Yoke	LM3433	LM3433	1
16	Retaining Ring	H5596	H5596	2
17	Shaft	396B	396B	1
18	Gate Latch	324DH9	324DH9	1
19	Nut	LM16	LM16	1
20	Hook	3M003C03	3M003C03	1
21	Hook & Yoke Assembly	335DHB	335DHB	1
22	Hook & Yoke Assembly	399DHB	3499DHB	1
†	Warning Decal (Not Shown)	649040344	649040344	1

* Yellow, 15' Long

** Blue, 12' Long



WARRANTY

Every hoist is thoroughly inspected and performance tested prior to shipment from the factory. If any properly installed, maintained and operated hoist as outlined in the applicable accompanying Little Mule manual develops a performance problem due to defective materials or workmanship as verified by Coffing Hoists/Little Mule, repair or replacement of the hoist will be made to the original purchaser without charge and the hoist will be returned, transportation prepaid. This warranty does not apply where deterioration is caused by normal wear, abuse, improper or

inadequate maintenance, eccentric or side loading, overloading, chemical or abrasive actions, excessive heat, unauthorized modifications or repairs, or use of non-Coffing/Little Mule repair parts. **EXCEPT AS STATED HEREIN, COFFING HOISTS/LITTLE MULE MAKES NO OTHER WARRANTIES, EXPRESS OR IMPLIED, INCLUDING WARRANTIES OF MERCHANTABILITY AND FITNESS FOR A PARTICULAR PURPOSE.**

WARNING

Overloading and Improper Use Can Result In Injury

To Avoid Injury:

- Do not exceed working load limit, load rating, or capacity.
- Do not use to lift people or loads over people.
- Read and follow all instructions.



Country Club Road • P.O. Box 779
Wadesboro, NC 28170 U.S.A
Phone 800-477-5003 • 704-694-2156
Fax 800-374-6853 • 704-694-6829